

Mechanical Data

- Surface Mount Package
- Weight: 1.55 grams (Approximate)
- Moisture Sensitivity Level 1
- Halogen Free Available Upon Request By Adding Suffix "-HF"
- Epoxy Meets UL 94 V-0 Flammability Rating
- Lead Free Finish/RoHS Compliant (Note1) ("P" Suffix Designates RoHS Compliant. See Ordering Information)

Note: 1. High Temperature Solder Exemption Applied, see EU Directive Annex 7a.

Package 3D Photo

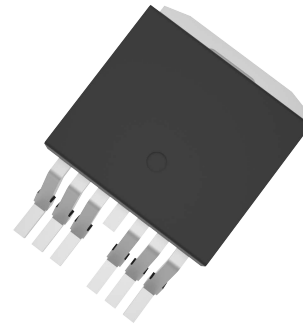

Package Outline Dimensions

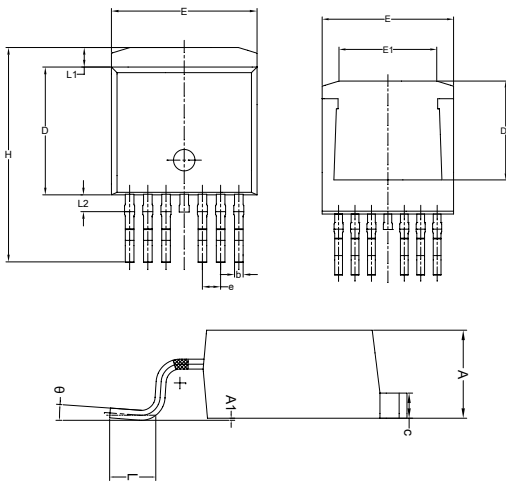

DIM	DIMENSIONS				NOTE
	INCHES		MM		
	MIN	MAX	MIN	MAX	
A	0.167	0.183	4.24	4.64	
A1	0.000	0.010	0.00	0.25	
b	0.020	0.035	0.50	0.90	
c	0.045	0.055	1.15	1.40	
D	0.347	0.364	8.82	9.25	
D1	0.270		6.86		
E	0.392	0.408	9.96	10.36	
E1	0.256	0.310	6.50	7.89	
e	0.050		1.27		TYP.
H	0.575	0.625	14.61	15.88	
L	0.070	0.110	1.78	2.79	
L1	0.039	0.056	0.98	1.42	
L2		0.070		1.78	
θ			0°	8°	

Suggested Solder Pad Layout

Unit:mm

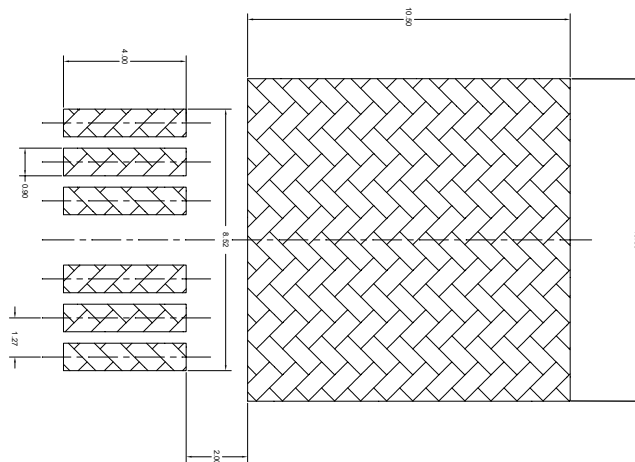

Notes:

- 1.The suggested land pattern dimensions have been provided for reference only.
- 2.For further information,please reference document IPC-7351A.

Packing Quantity

Package	Tape Width (mm)	Reel Size (inch)	Reel Quantity	BOX Quantity	Carton Quantity
TO-263-7	24	13	800	800	4K

Note 1: These are minimum package quantities only. Minimum orders will differ. Contact the factory for more information on minimum order quantities.

Note 2: MCC Tape&reel products meets EIA-481 REV D specification.

Device Tape Orientation

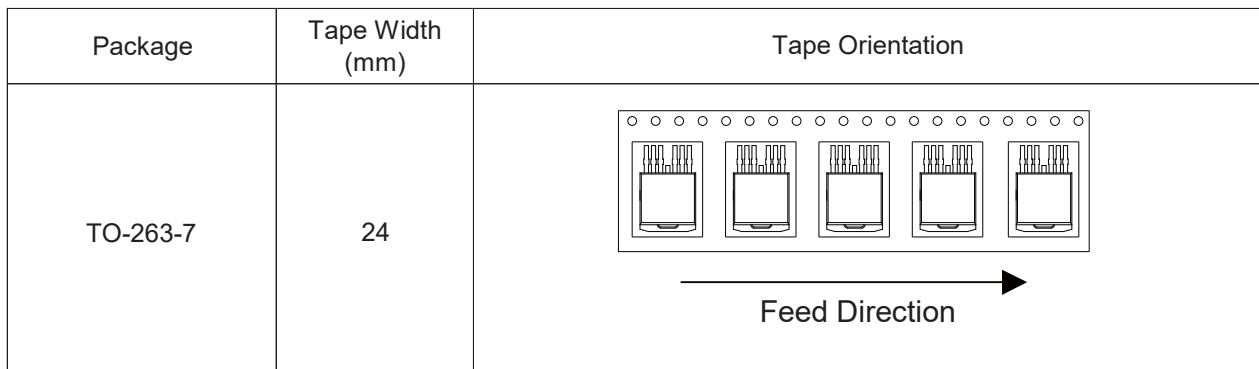

Embossed Carrier Tape Specifications

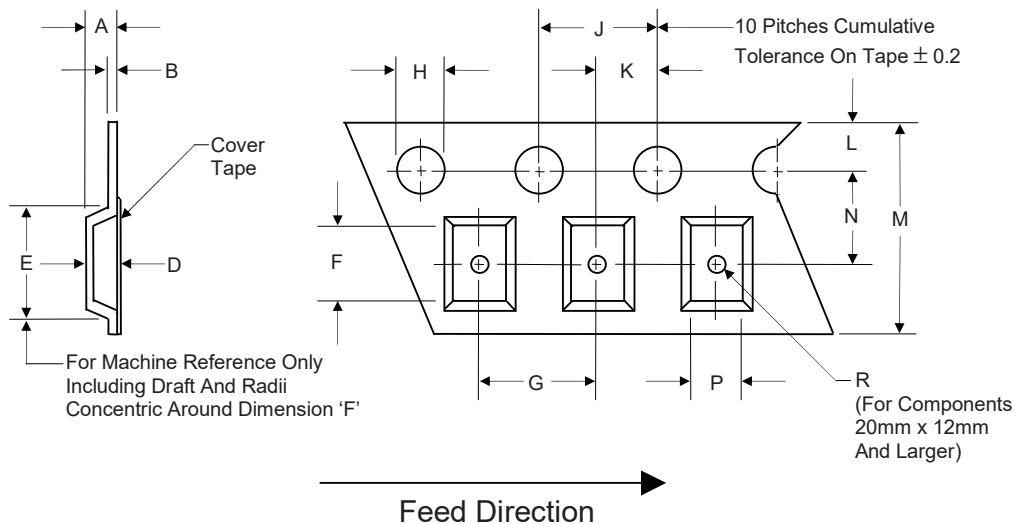

Tape Width	H	L	J	B	D	F	P
24mm	1.5	1.75	4.0	0.5	See Note 3		
(Tolerance)	+0.1/-0	±0.1	±0.1	Max			

Tape Width	E	R	N	A	K	M	G
24mm	20.1	1.5	11.5	6.1	2.0	24.0	16.0
(Tolerance)	Max	Min	± 0.10	Max	± 0.10	±0.3	±0.1

Note 3: D,E,F are determined by constant size. The clearance between the part and the tape cavity must be within 0.05mm min. to 1.20mm max. for 24mm tape.

Embossed Carrier Tape Specifications



Tape Size	R Min.
21mm	30mm

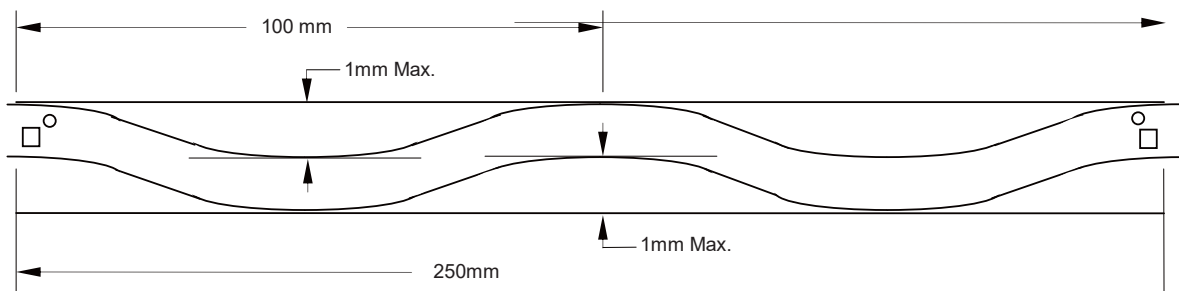

Camber (Top View)

Allowable camber to be 1mm/100mm non-accumulative over 250mm

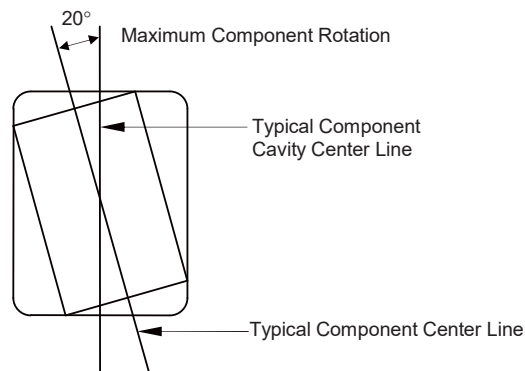

Start and Finish Specification

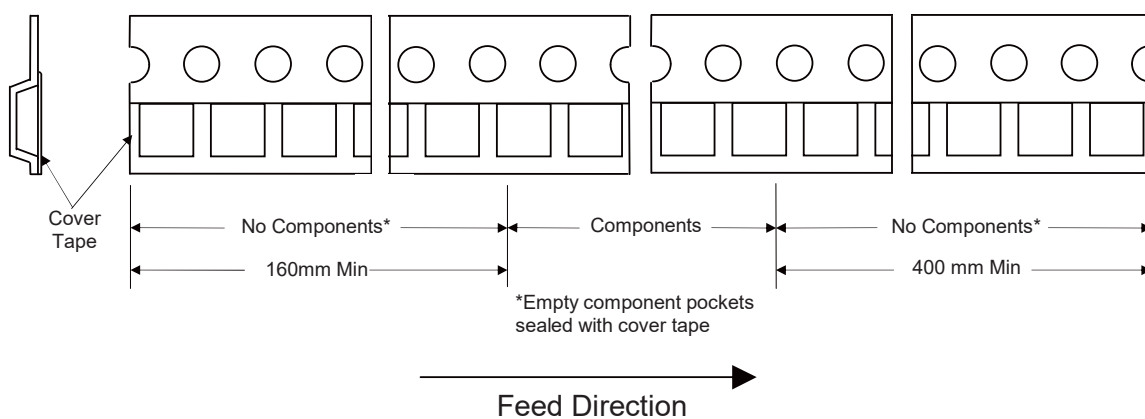

Surface Mount Reel Specifications

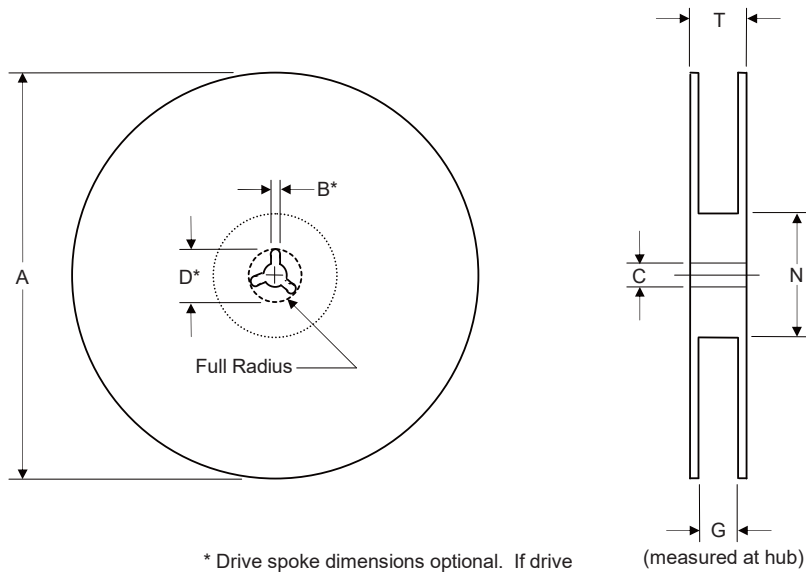

* Drive spoke dimensions optional. If drive spoke is used then asterisked dimensions apply.

Tape Width	A	B	C	D	N	G	T
24mm	335	1.5	5.8	20.2	99	24.4	31.4
(Tolerance)	Max	Min	±0.2	Min	Min	+2.0	Max

Reel Dimensions

Inbox Size

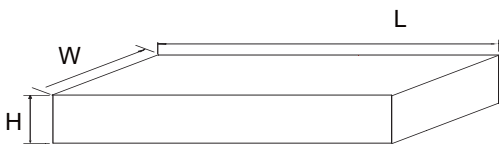

Description	Dimension	Specification(mm typical)
Length	L	365
Width	W	345
Height	H	50

Carton Size

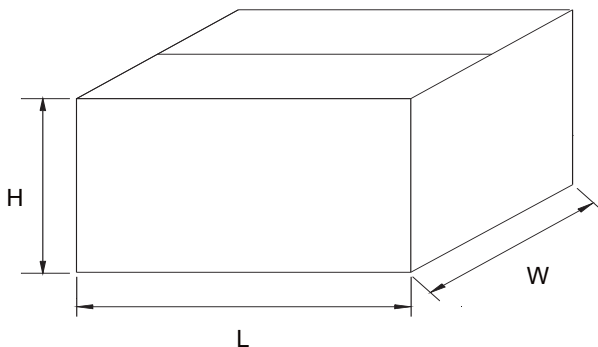

Description	Dimension	Specification(mm typical)
Length	L	387
Width	W	275
Height	H	360

Packing Quantity

Package	Package Type	Tube Quantity	Box Quantity	Carton Quantity
TO-263-7	Tube	50	1000	5000

Note 1: These are minimum package quantities only. Minimum orders will differ. Contact the factory for more information on minimum order quantities.

Dimensions

Tube Size

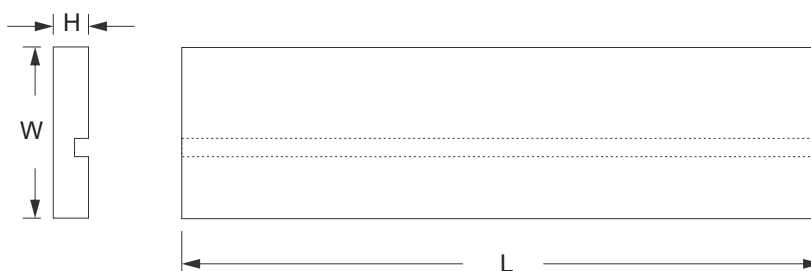

Description	Dimension	Specification(mm typical)
Length	L	530
Width	W	33
Height	H	7

Inbox Size

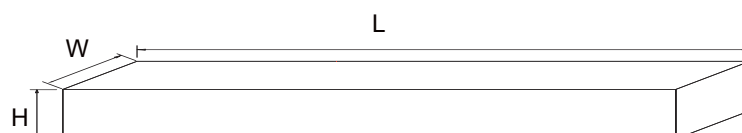

Description	Dimension	Specification(mm typical)
Length	L	560
Width	W	150
Height	H	40

Carton Size

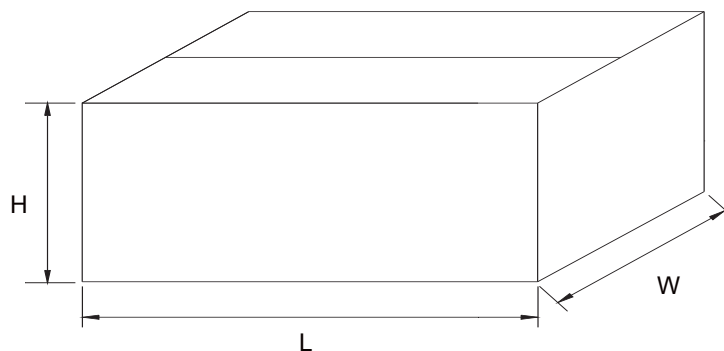

Description	Dimension	Specification(mm typical)
Length	L	570
Width	W	210
Height	H	175