

**Mechanical Data**

- Surface Mount Package
- Weight: 0.0110 grams (Approximate)
- Moisture Sensitivity Level 1
- Halogen Free Available Upon Request By Adding Suffix "-HF"
- Epoxy Meets UL 94 V-0 Flammability Rating
- Lead Free Finish/RoHS Compliant <sup>(Note1)</sup> ("P" Suffix Designates RoHS Compliant. See Ordering Information)

Note: 1. High Temperature Solder Exemption Applied, see EU Directive Annex 7a.

**Package 3D Photo**

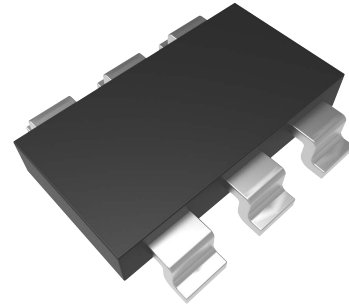

**Package Outline Dimensions**

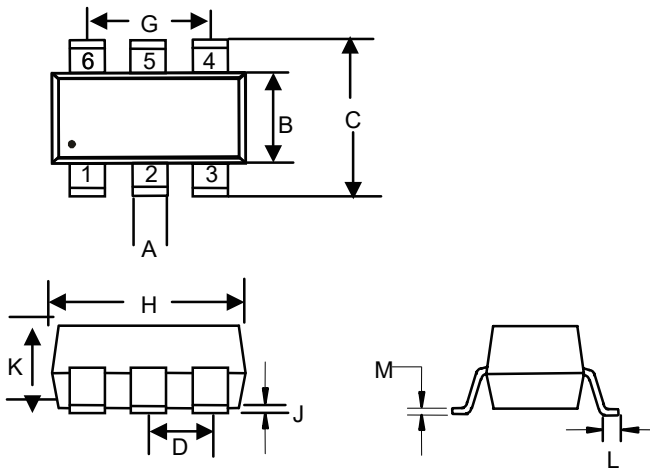

DIM	DIMENSIONS				NOTE
	INCHES		MM		
A	0.012	0.020	0.30	0.50	
B	0.051	0.070	1.30	1.80	
C	0.087	0.126	2.20	3.20	
D	0.037		0.95		TYP.
G	0.074		1.90		TYP.
H	0.106	0.122	2.70	3.10	
J	0.002	0.006	0.05	0.15	
K	0.030	0.051	0.75	1.30	
L	0.012	0.024	0.30	0.60	
M	0.003	0.008	0.08	0.22	

**Suggested Solder Pad Layout**

Unit:mm

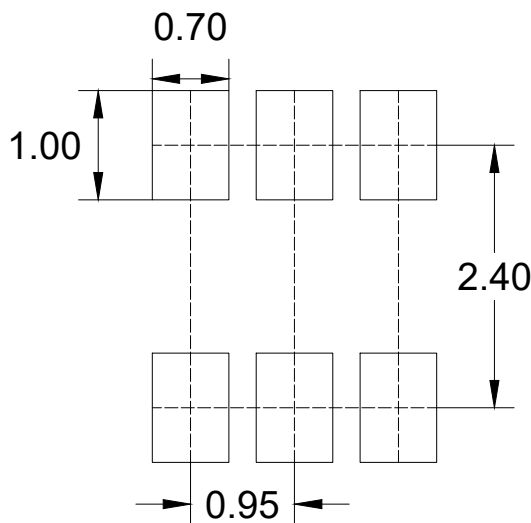

Notes:

- 1.The suggested land pattern dimensions have been provided for reference only.
- 2.For further information,please reference document IPC-7351A.

**Packing Quantity**

Package	Tape Width (mm)	Reel Size (inch)	Reel Quantity	BOX Quantity	Carton Quantity
SOT23-6L	8	7	3000	30K	120K

Note 1: These are minimum package quantities only. Minimum orders will differ. Contact the factory for more information on minimum order quantities.

Note 2: MCC Tape&reel products meets EIA-481 REV D specification.

**Device Tape Orientation**

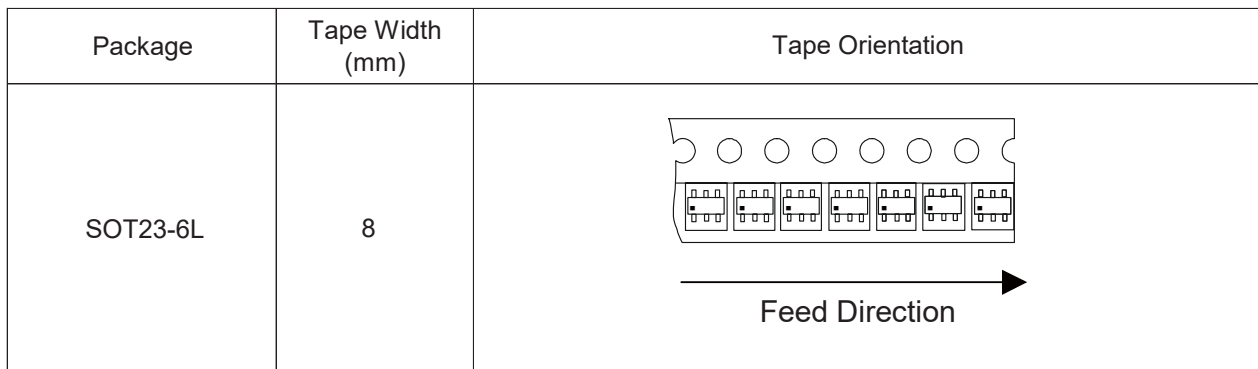

**Embossed Carrier Tape Specifications**

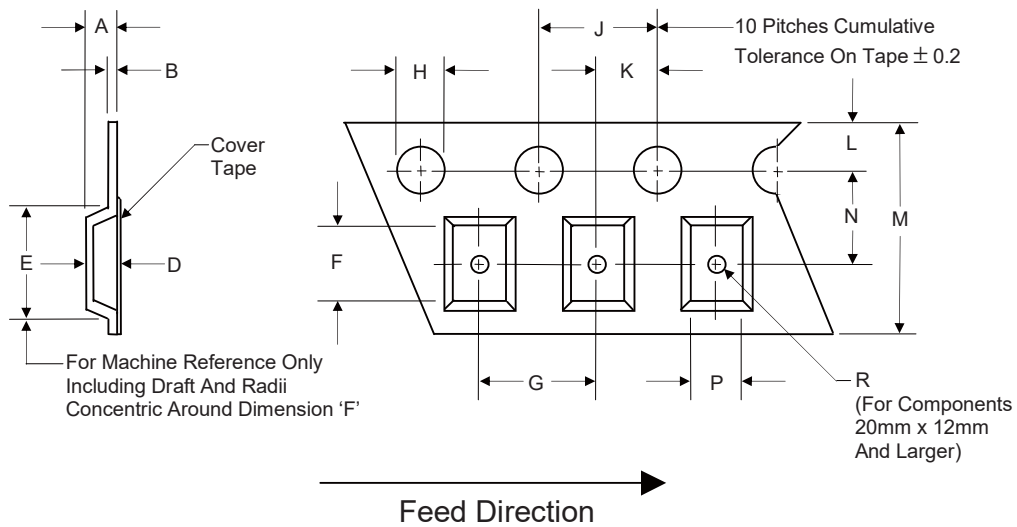

Tape Width	H	L	J	B	D	F	P
8mm	1.5	1.75	4.0	0.6	See Note 3		
(Tolerance)	+0.1/-0	±0.1	±0.1	Max			

Tape Width	E	R	N	A	K	M	G
8mm	4.2	1.0	3.5	2.4	2.0	8.0	4.0
(Tolerance)	Max	Min	±0.05	Max	±0.05	±0.3	±0.1

Note 3: D,E,F are determined by constant size. The clearance between the part and the tape cavity must be within 0.05mm min. to 0.50mm max. for 8mm tape.

## Embossed Carrier Tape Specifications



Tape Size	R Min.
8mm	25mm

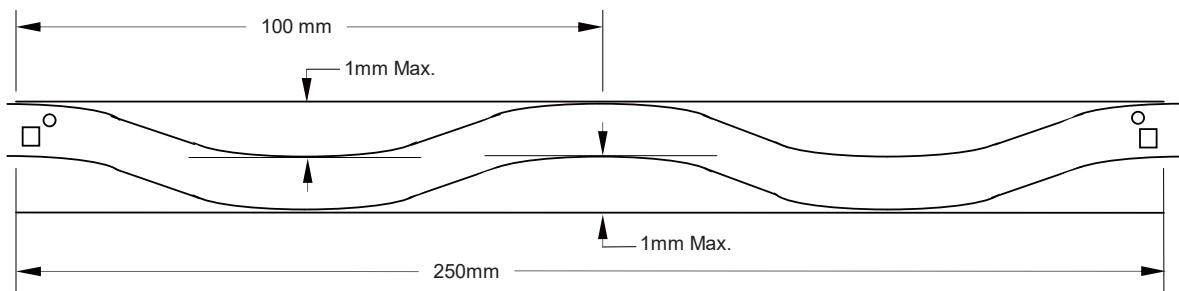

Camber (Top View)

Allowable camber to be 1mm/100mm non-accumulative over 250mm

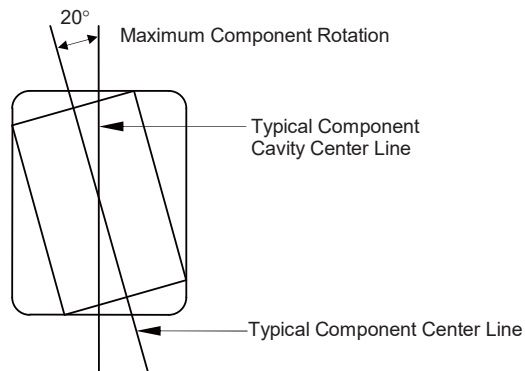

## Start and Finish Specification

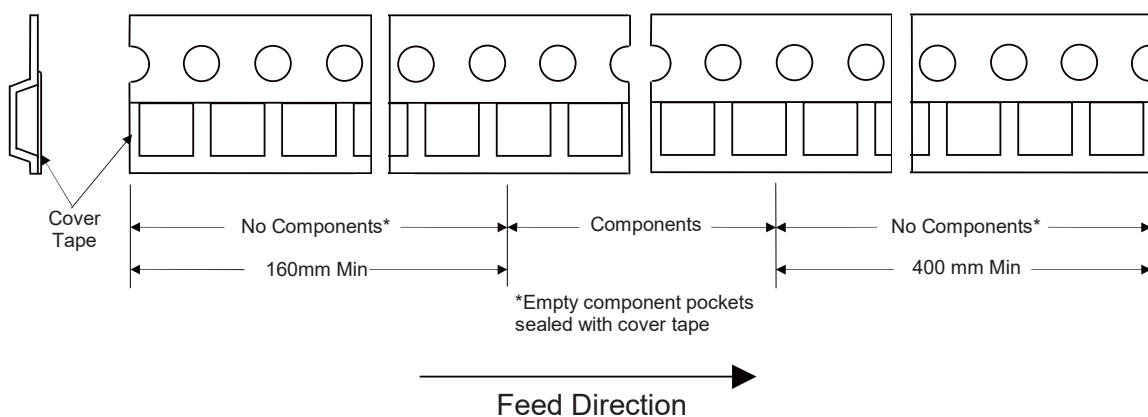

## Surface Mount Reel Specifications

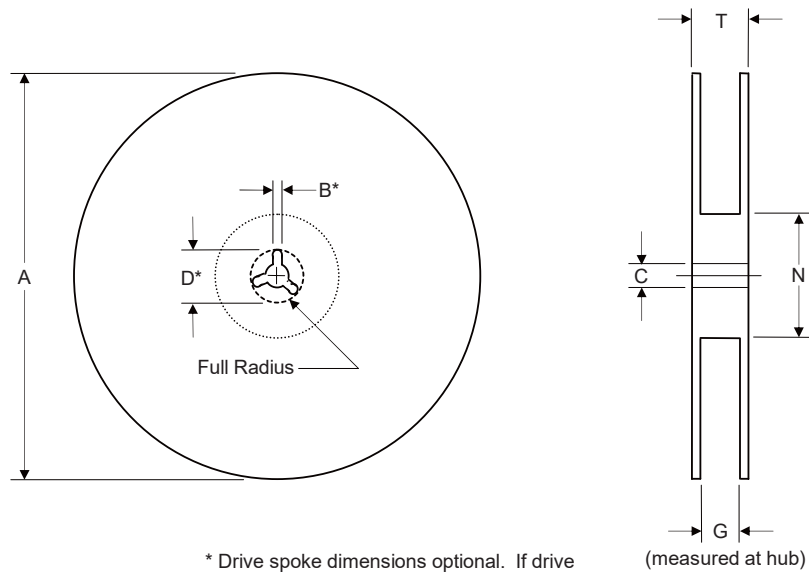

\* Drive spoke dimensions optional. If drive spoke is used then asterisked dimensions apply.

Tape Width	A	B	C	D	N	G	T
8mm	180	1.5	13.0	20.2	55	8.4	14.4
(Tolerance)	Max	Min	±0.2	Min	±5.0	+1.5	Max

## Dimensions

### Inbox Size

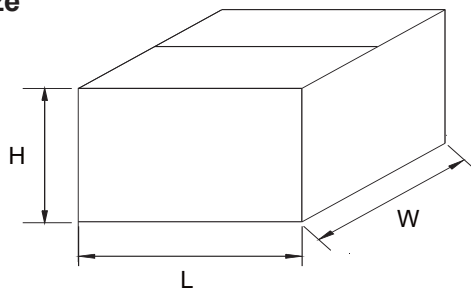

Dimension	Specification(mm typical)	
	General	MBB Bag
L	187	227
W	130	145
H	187	202

### Carton Size

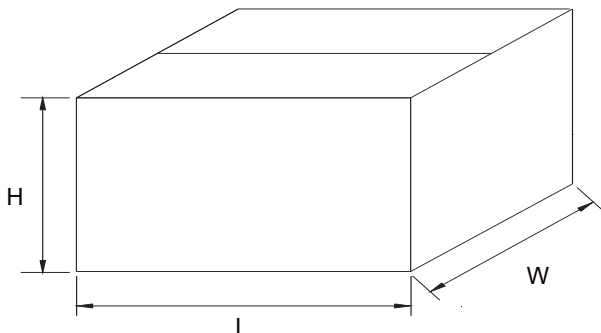

Dimension	Specification(mm typical)	
	General	MBB Bag
L	390	470
W	275	305
H	207	223