

Mechanical Data

- Surface Mount Package
- Weight: 0.6200 grams (Approximate)
- Moisture Sensitivity Level 1
- Halogen Free. "Green" Device (Note 1)
- Epoxy Meets UL 94 V-0 Flammability Rating
- Lead Free Finish/RoHS Compliant (Note2) ("P" Suffix Designates RoHS Compliant. See Ordering Information)

Note:1. free "Green" products are defined as those which contain <900ppm bromine, <900ppm chlorine (<1500ppm total Br + Cl) and <1000ppm antimony compounds.
2. High Temperature Solder Exemption Applied, see EU Directive Annex 7a.

Package 3D Photo

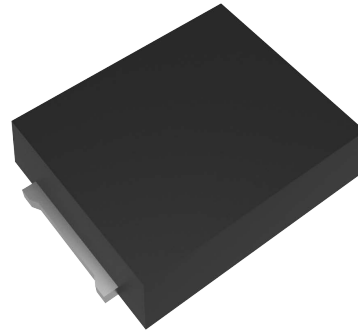

Package Outline Dimensions

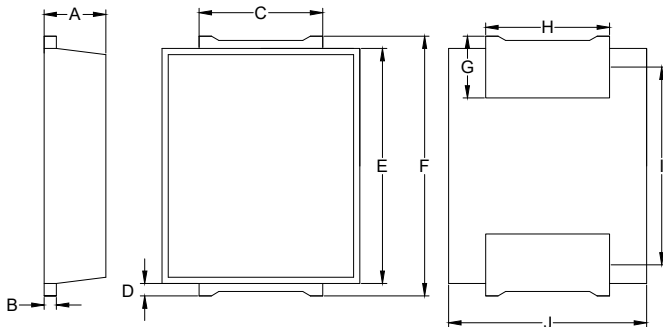

DIMENSIONS					
DIM	INCHES		MM		NOTE
	MIN	MAX	MIN	MAX	
A	0.096	0.100	2.45	2.55	
B	0.018	0.022	0.45	0.55	
C	0.193	0.201	4.90	5.10	
D	0.016	0.024	0.40	0.60	
E	0.370	0.378	9.40	9.60	
F	0.406	0.421	10.30	10.70	
G	0.094	0.102	2.40	2.60	
H	0.193	0.201	4.90	5.10	
J	0.311	0.319	7.90	8.10	
I	0.311	0.319	7.90	8.10	

Suggested Solder Pad Layout

Unit:mm

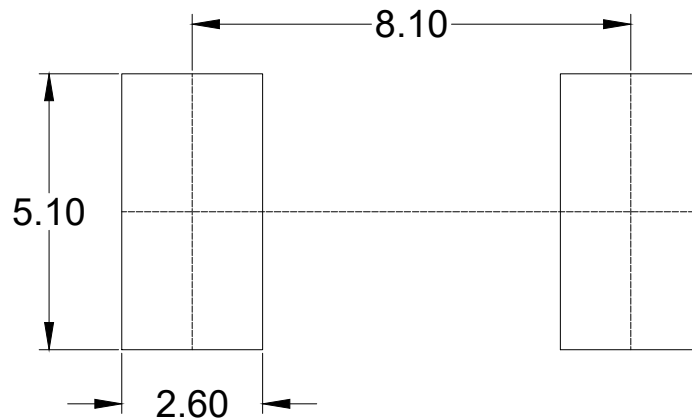

Notes:

- 1.The suggested land pattern dimensions have been provided for reference only.
- 2.For further information,please reference document IPC-7351A.

Packing Quantity

Package	Tape Width (mm)	Reel Size (inch)	Reel Quantity	BOX Quantity	Carton Quantity
SMG	24	15	1500	1500	4500

Note 1: These are minimum package quantities only. Minimum orders will differ. Contact the factory for more information on minimum order quantities.

Note 2: MCC Tape&reel products meets EIA-481 REV D specification.

Device Tape Orientation

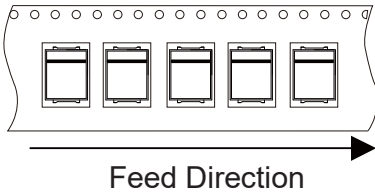
Package	Tape Width (mm)	Tape Orientation
SMG	24	

Embossed Carrier Tape Specifications

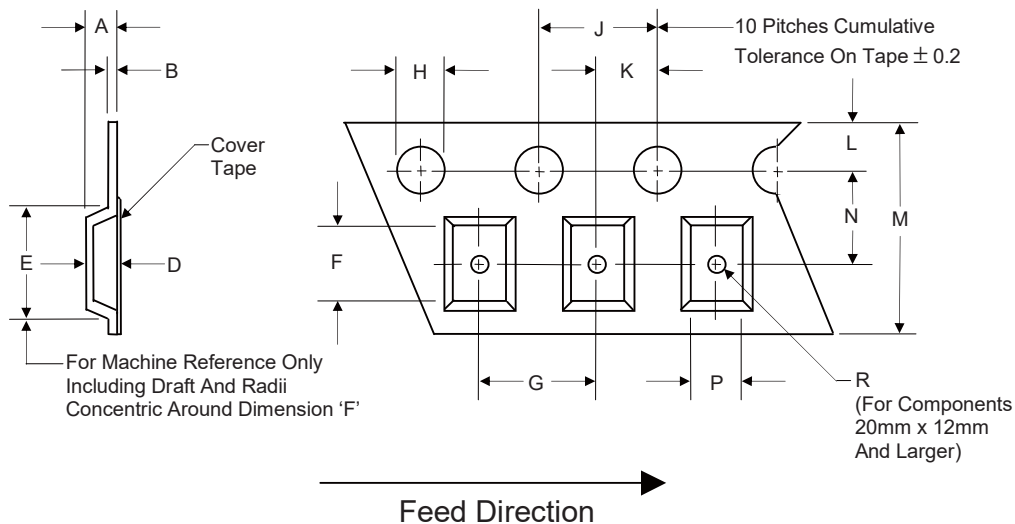

Tape Width	H	L	J	B	D	F	P
24mm	1.5	1.75	4.0	0.6	See Note 3		
(Tolerance)	+0.1/-0	±0.1	±0.1	Max			

Tape Width	E	R	N	A	K	M	G
24mm	12.1	1.5	11.5	6.5	2.0	24.0	12.0
(Tolerance)	Max	Min	±0.10	Max	±0.10	±0.3	±0.1

Note 3: D,E,F are determined by constant size. The clearance between the part and the tape cavity must be within 0.05mm min. to 1.20mm max. for 24mm tape.

Embossed Carrier Tape Specifications

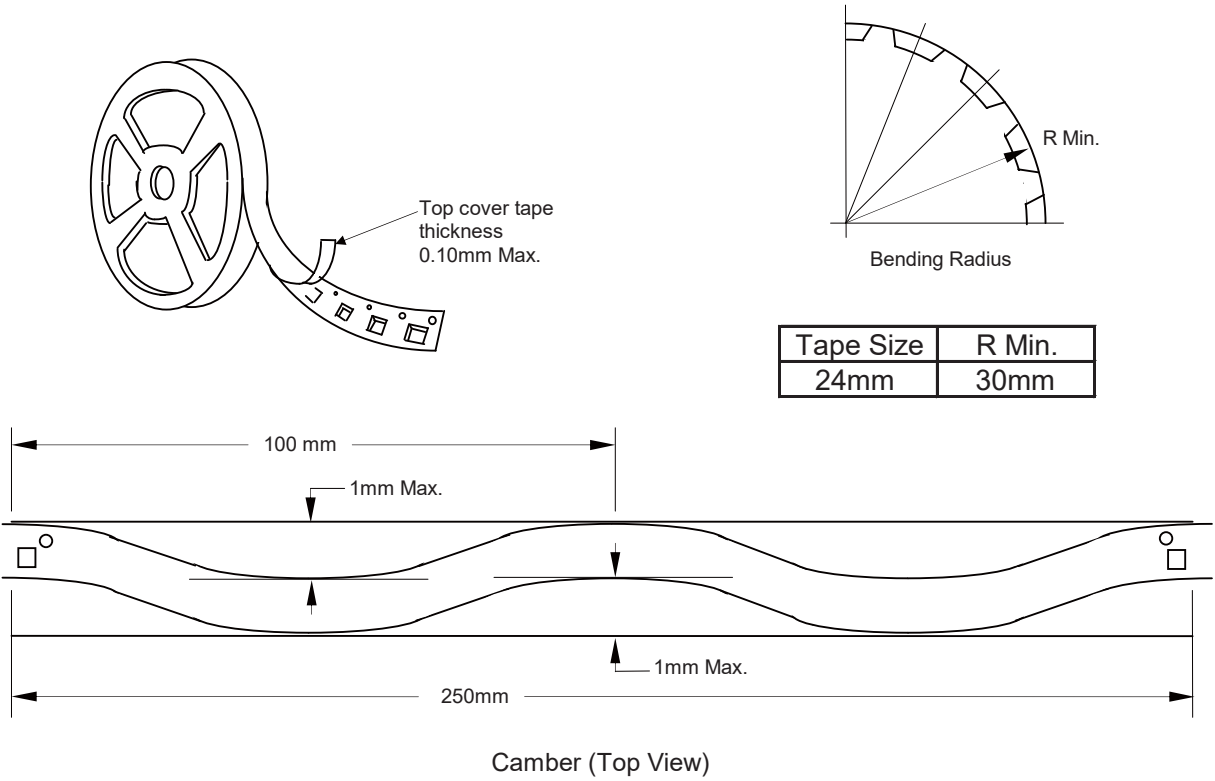

Allowable camber to be 1mm/100mm non-accumulative over 250mm

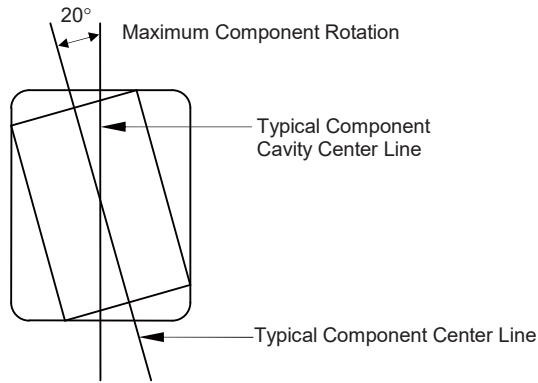

Start and Finish Specification

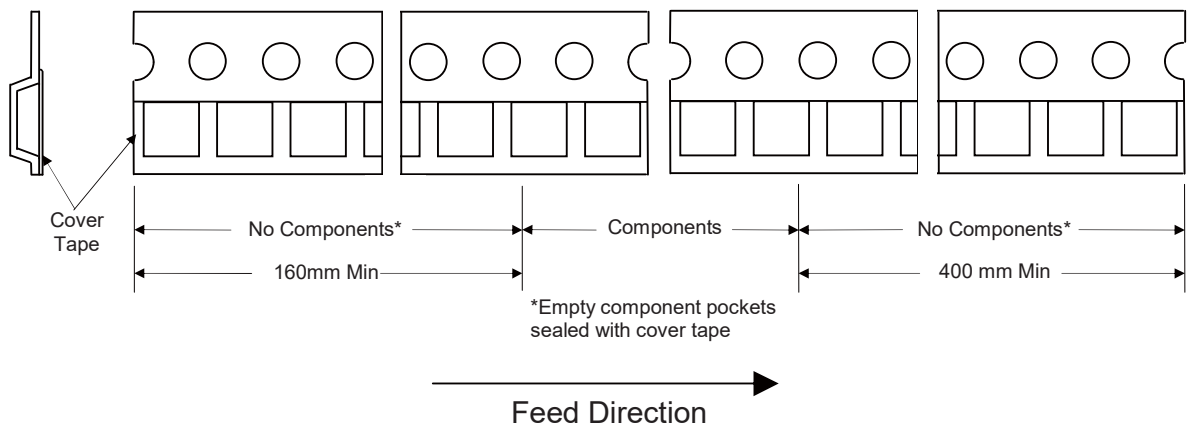

Surface Mount Reel Specifications

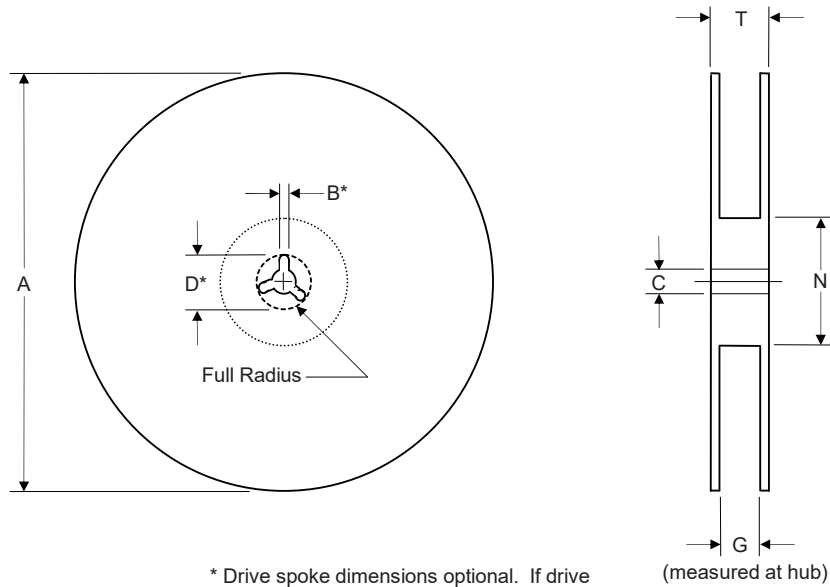

Tape Width	A	B	C	D	N	G	T
24mm	380	1.5	12.5	20.2	55	27.5	32.5
(Tolerance)	+2.0	Min	±2.0	Min	Min	+2.0	+2.0

Dimensions

Inbox Size

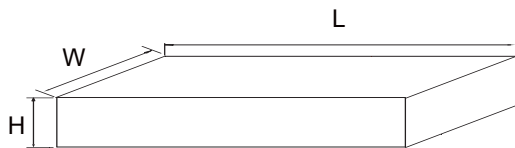

Description	Dimension	Specification(mm typical)
Length	L	400
Width	W	390
Height	H	35

Carton Size

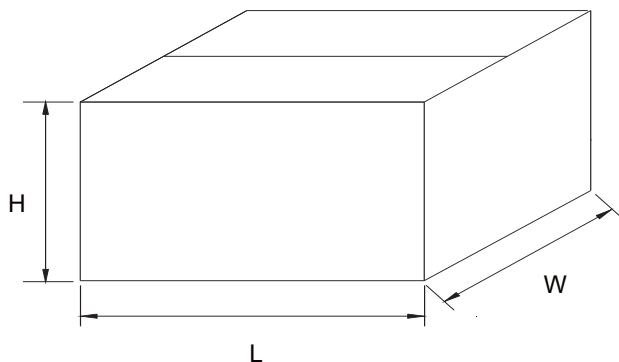

Description	Dimension	Specification(mm typical)
Length	L	420
Width	W	410
Height	H	120