

Packing Quantity and Device Tape Orientation

Package	Tape Width mm	Reel Size inch	Pitch mm	Packing Quantity			ESD/MBB Bag	Pin1 Position	Tape Orientation Feed Direction →	OPN Suffix
				Reel kpcs	Inner Box kpcs	Carton kpcs				
				PDFN5060-DSC-B	12	13			8	

Note 1: All MOSFETs and other MSL3 products come with an ESD/MBB bag.

Note 2: These are minimum package quantities only. Minimum order quantities may vary. Please contact your sales representative for more information on minimum order quantities.

Note 3: MCC Tape&reel products meets EIA-481 specification.

Note 4: Please refer to the product datasheet for MSL level, RoHS and Halogen-Free compliance.

Note 5: Orientation guide for commonly used devices.

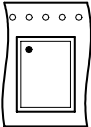
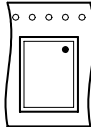
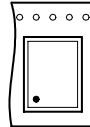
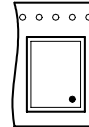
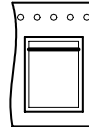
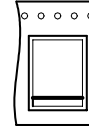
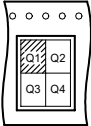
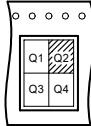
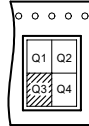
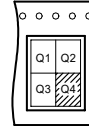
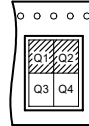
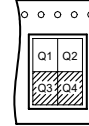
Pin1 Position	Q1	Q2	Q3	Q4	Q1Q2	Q3Q4
Orientation in Carrier						
Termination 1 Orientation by Quadrant						

Embossed Carrier Tape Specifications

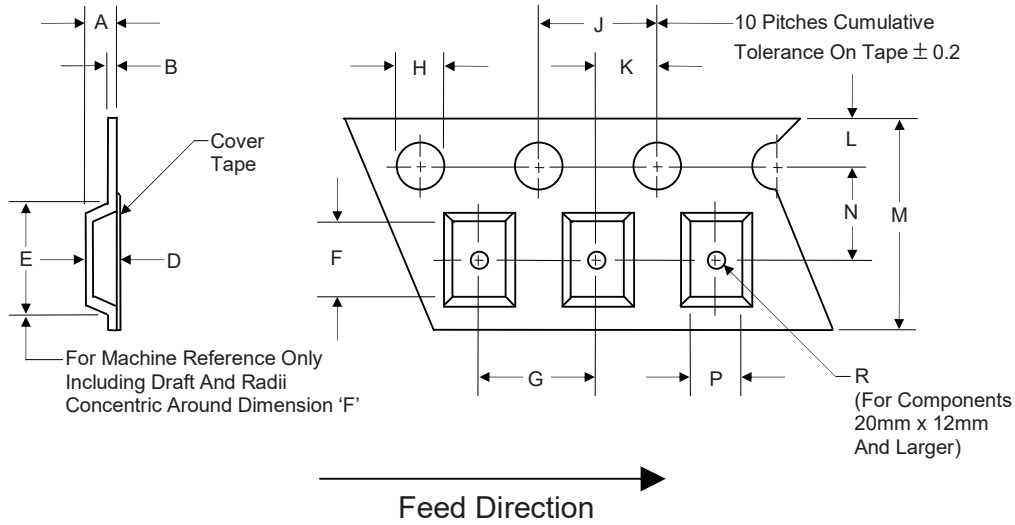

Tape Width	H	L	J	B	D	F	P
12mm	1.5	1.75	4.0	0.27	See Note 3		
(Tolerance)	+0.25/-0	± 0.1	± 0.1	Max			

Tape Width	E	R	N	A	K	M	G
12mm	6.0	1.5	5.5	1.2	2.0	12.0	8.0
(Tolerance)	Max	Min	± 0.1	Max	± 0.05	+0.3/-0.1	± 0.1

Note 3: D,E,F are determined by constant size. The clearance between the part and the tape cavity must be within 0.05mm min. to 0.65mm max. for 12mm tape.

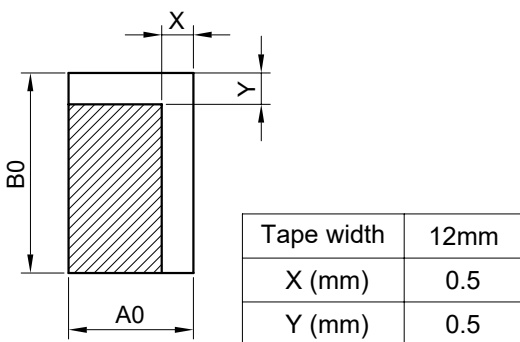

Maximum Lateral movement

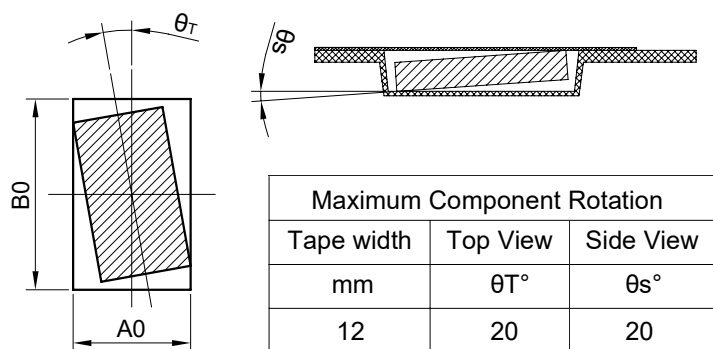

Maximum Component Rotation

Embossed Carrier Tape Specifications



Tape Size	R Min.
12mm	30mm

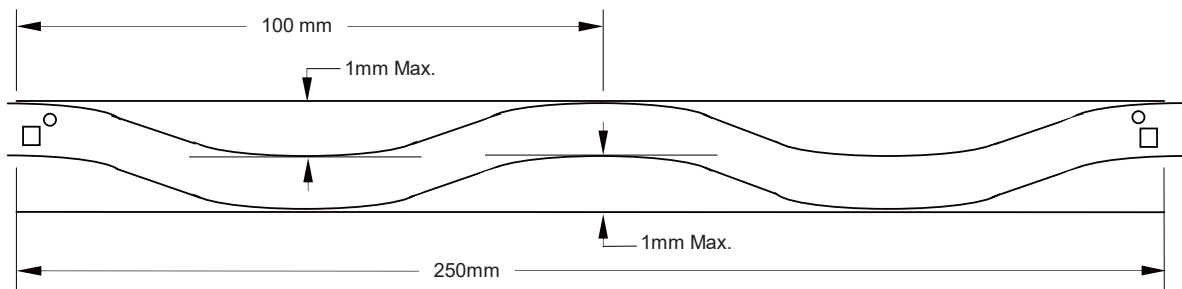

Camber (Top View)

Allowable camber to be 1mm/100mm non-accumulative over 250mm

Start and Finish Specification

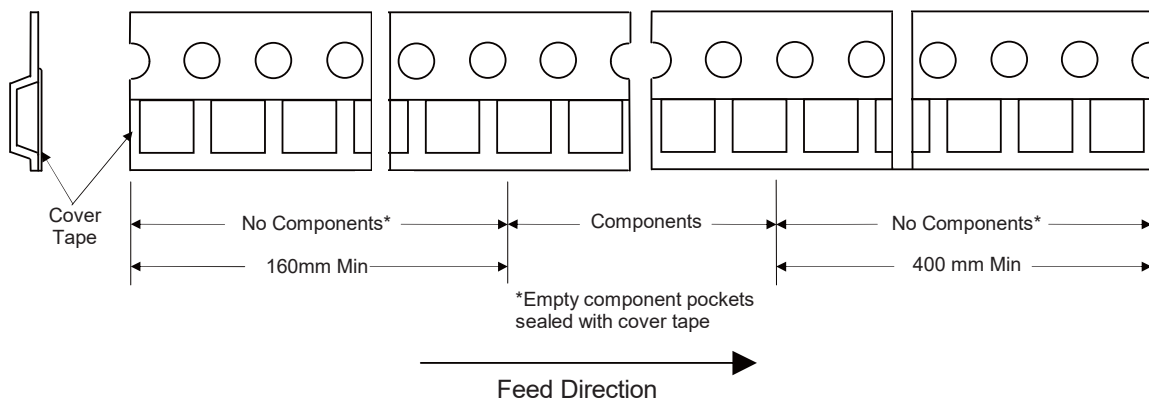

Surface Mount Reel Specifications

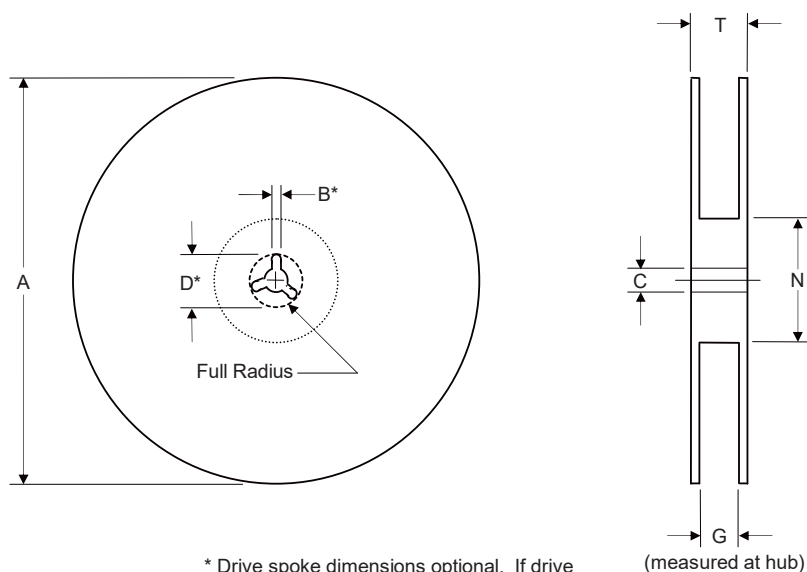

* Drive spoke dimensions optional. If drive spoke is used then asterisked dimensions apply.

Tape Width	A	B	C	D	N	G	T
12mm	330	1.5	13.0	21.5	99	12.4	20.6
(Tolerance)	±2.0	Min	±0.2	Min	Min	+2.0	Max

Dimensions

Inbox Size

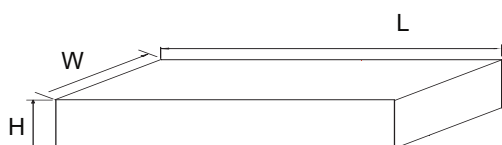

Description	Dimension	Specification(mm typical)
Length	L	370
Width	W	340
Height	H	55

Carton Size

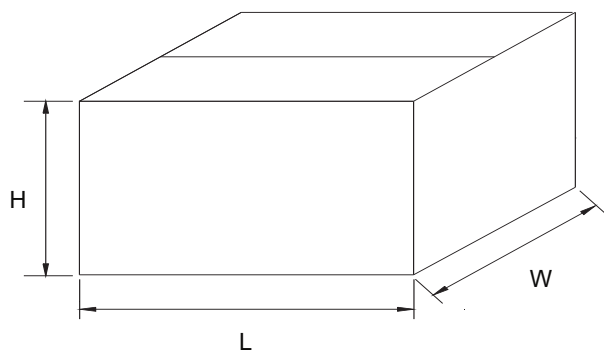

Description	Dimension	Specification(mm typical)
Length	L	385
Width	W	365
Height	H	315