

Mechanical Data

- Surface Mount Package
- Weight: 0.1400 grams (Approximate)
- Moisture Sensitivity Level Refer to Product Datasheet
- Halogen Free. "Green" Device (Note1)
- Epoxy Meets UL 94 V-0 Flammability Rating
- Lead Free Finish/RoHS Compliant (Note2) ("P" Suffix Designates RoHS Compliant. See Ordering Information)

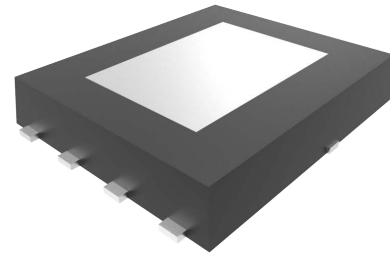

Note:1. free "Green" products are defined as those which contain <900ppm bromine, <900ppm chlorine (<1500ppm total Br + Cl) and <1000ppm antimony compounds.
2. High Temperature Solder Exemption Applied, see EU Directive Annex 7a.

Package Outline Dimensions

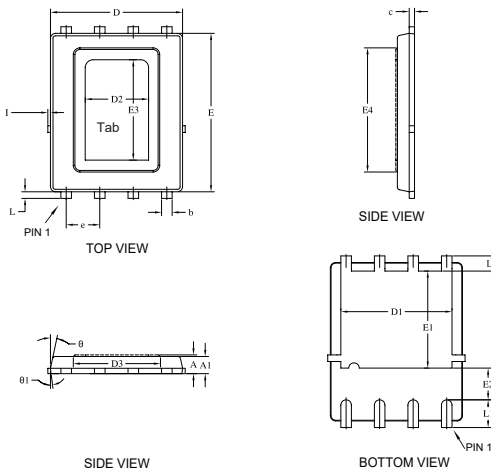

DIM	DIMENSIONS				NOTE
	INCHES		MM		
A	0.026	0.030	0.66	0.76	
A1	0.024	0.030	0.60	0.75	
b	0.013	0.021	0.33	0.53	
c	0.006	0.012	0.15	0.30	
D	0.197		5.00		Bsc
D1	0.160	0.172	4.06	4.36	
D2	0.094		2.40		Bsc
D3	0.110	0.150	2.80	3.80	
E	0.236		6.00		Bsc
E1	0.139	0.151	3.53	3.83	
E2	0.041	0.053	1.05	1.35	
E3	0.150		3.80		Bsc
E4	0.165	0.205	4.20	5.20	
e	0.050		1.27		Bsc
l	---	0.006	---	0.15	
L	0.006	0.014	0.15	0.35	
L1	0.037	0.046	0.93	1.18	
L2	0.018	0.028	0.45	0.70	
θ					12°Bsc
θ1					7°Bsc

Suggested Solder Pad Layout

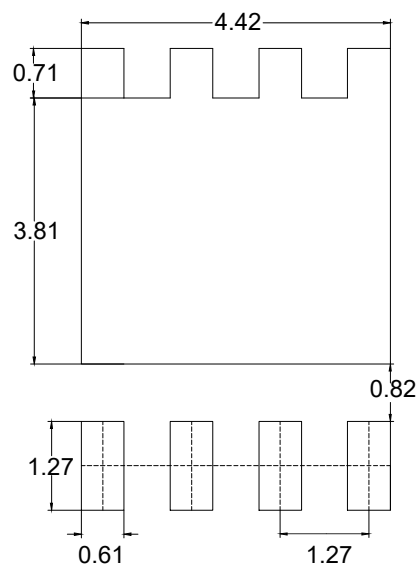

Unit:mm

Notes:

- 1.The suggested land pattern dimensions have been provided for reference only.
- 2.For further information,please reference document IPC-7351A.

Packing Quantity

Package	Tape Width (mm)	Reel Size (inch)	Reel Quantity	BOX Quantity	Carton Quantity
DFN5060-DSC	12	13	5000	10K	50K

Note 1: These are minimum package quantities only. Minimum orders will differ. Contact the factory for more information on minimum order quantities.

Note 2: MCC Tape&reel products meets EIA-481 REV D specification.

Device Tape Orientation

Package	Tape Width (mm)	Tape Orientation
DFN5060-DSC	12	

Embossed Carrier Tape Specifications

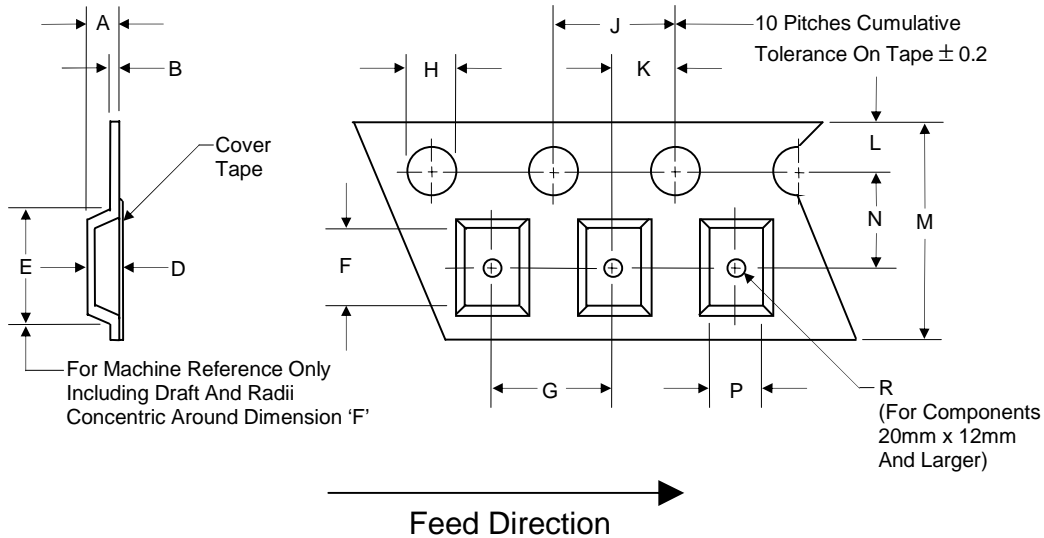

Tape Width	H	L	J	B	D	F	P
12mm	1.5	1.75	4.0	0.6	See Note 3		
(Tolerance)	+0.1/-0	±0.1	±0.1	Max			

Tape Width	E	R	N	A	K	M	G
12mm	8.2	1.5	5.5	4.5	2.0	12.0	8.0
(Tolerance)	Max	Min	±0.05	Max	±0.05	±0.3	±0.1

Note 3: D,E,F are determined by constant size. The clearance between the part and the tape cavity must be within 0.05mm min. to 0.65mm max. for 12mm tape.

Embossed Carrier Tape Specifications

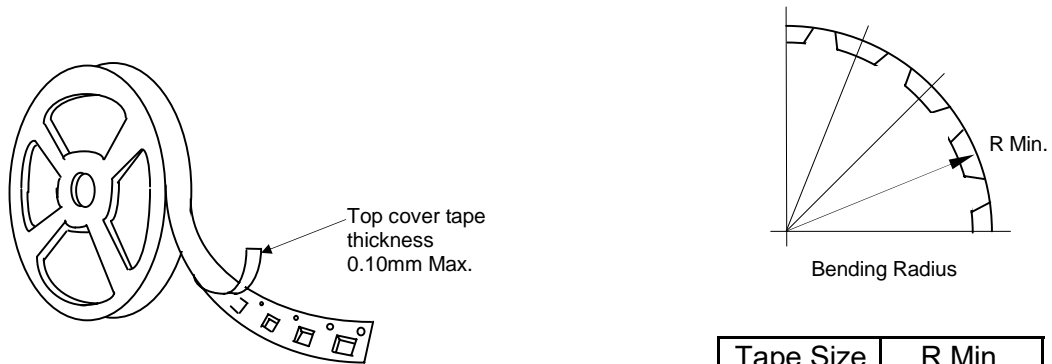

Tape Size	R Min.
12mm	30mm

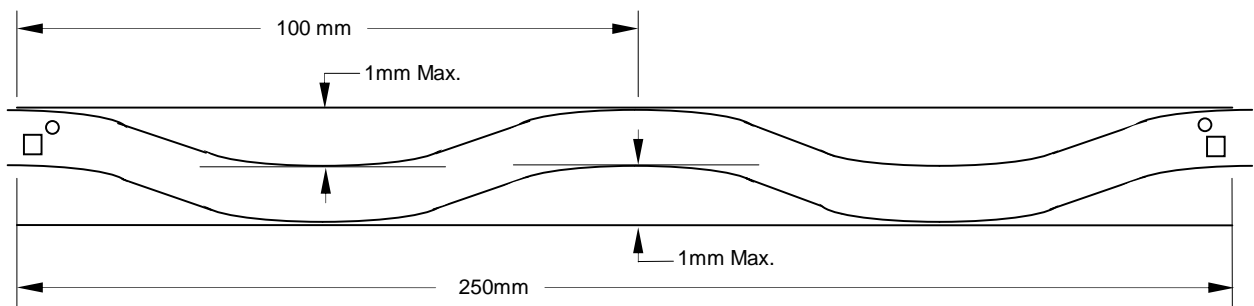

Camber (Top View)

Allowable camber to be 1mm/100mm non-accumulative over 250mm

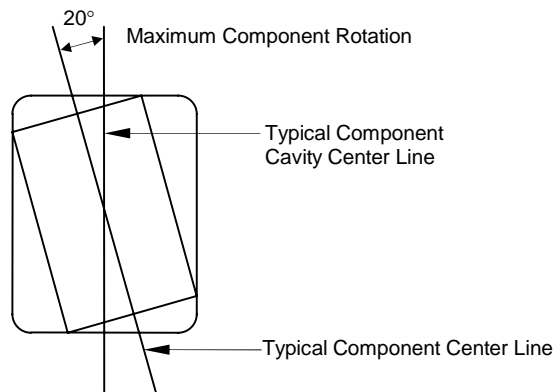

Start and Finish Specification

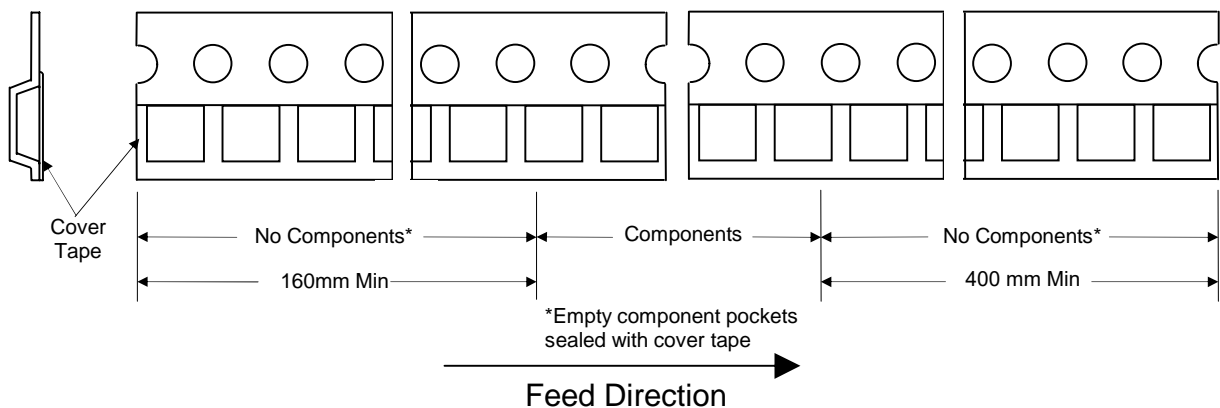

Surface Mount Reel Specifications

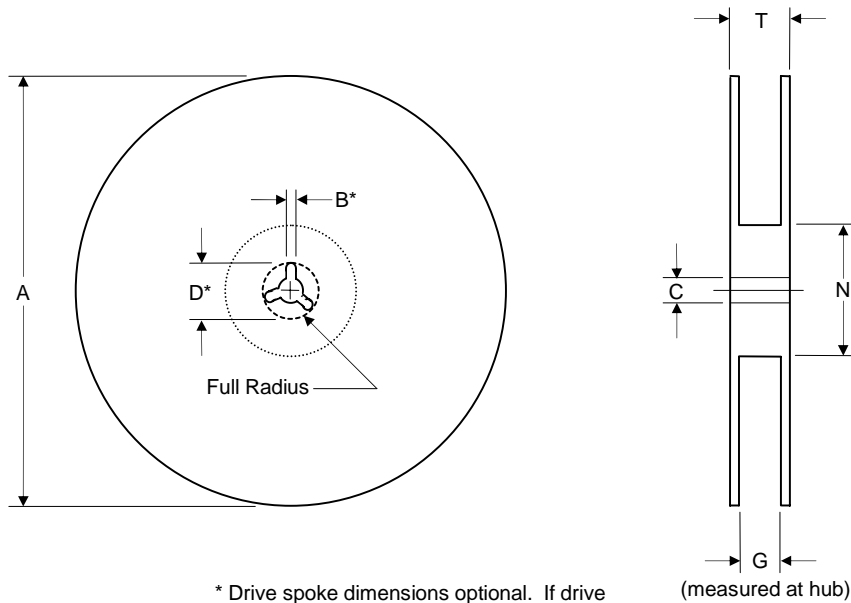

* Drive spoke dimensions optional. If drive spoke is used then asterisked dimensions apply.

Tape Width	A	B	C	D	N	G	T
12mm	330	1.5	13.0	20.2	55	12.4	18.4
(Tolerance)	±2.0	Min	±0.2	Min	Min	+2.0	Max

Dimensions

Inbox Size

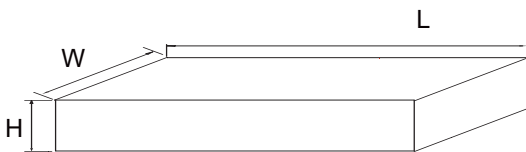

Description	Dimension	Specification(mm typical)
Length	L	370
Width	W	340
Height	H	55

Carton Size

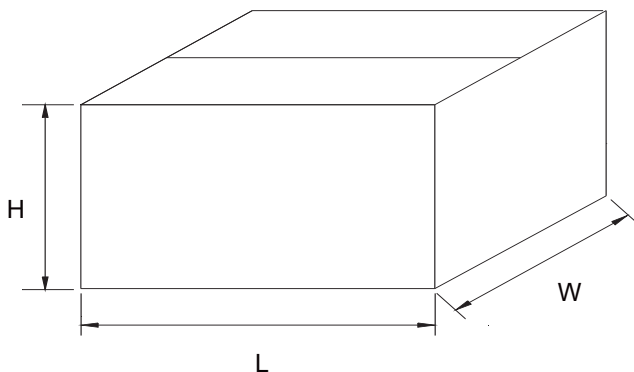

Description	Dimension	Specification(mm typical)
Length	L	385
Width	W	365
Height	H	315