

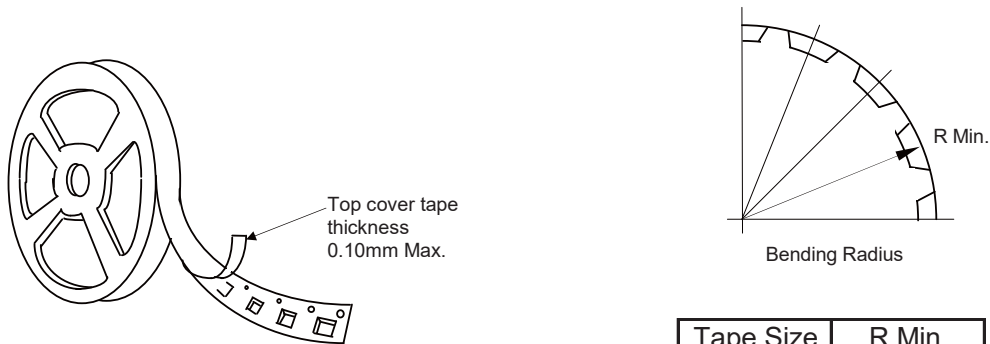

## Embossed Carrier Tape Specifications

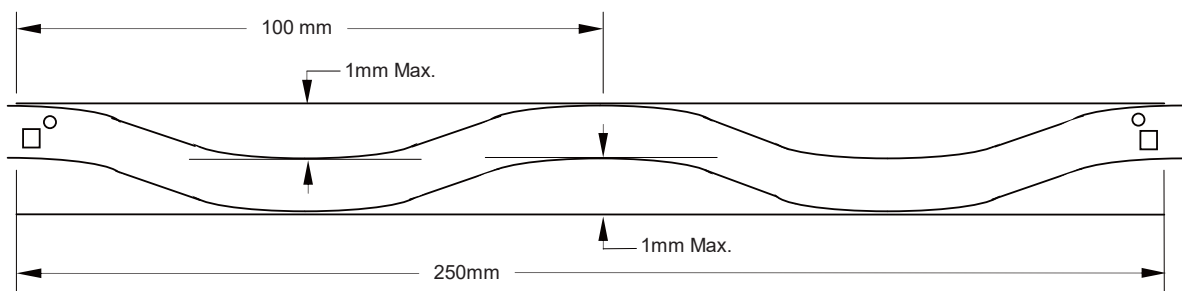

Tape Size	R Min.
8mm	25mm



Camber (Top View)

Allowable camber to be 1mm/100mm non-accumulative over 250mm

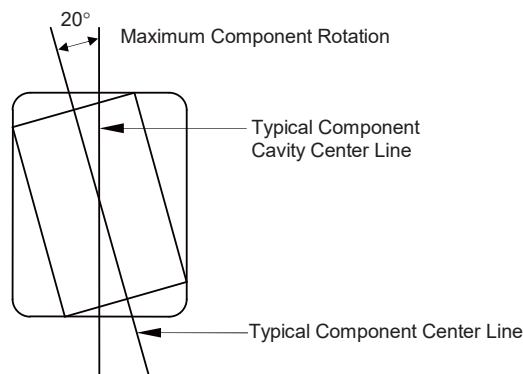

## Start and Finish Specification

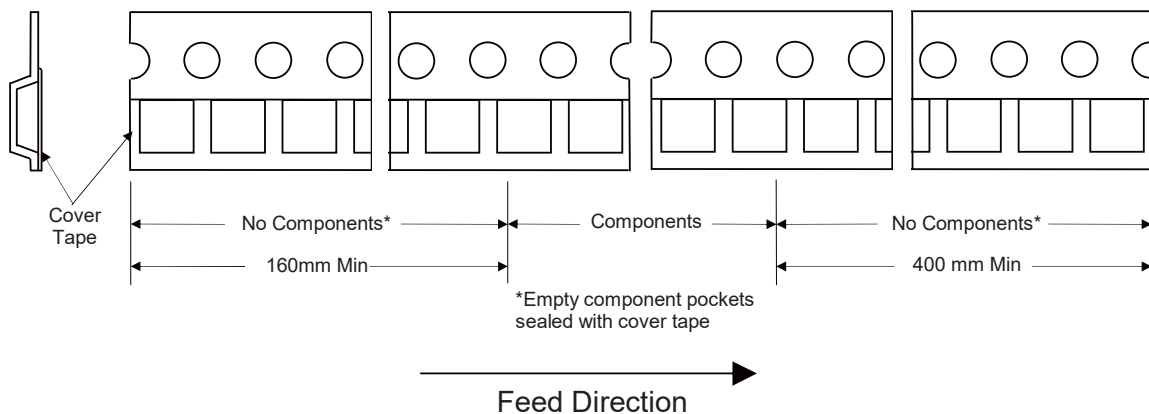

## Surface Mount Reel Specifications

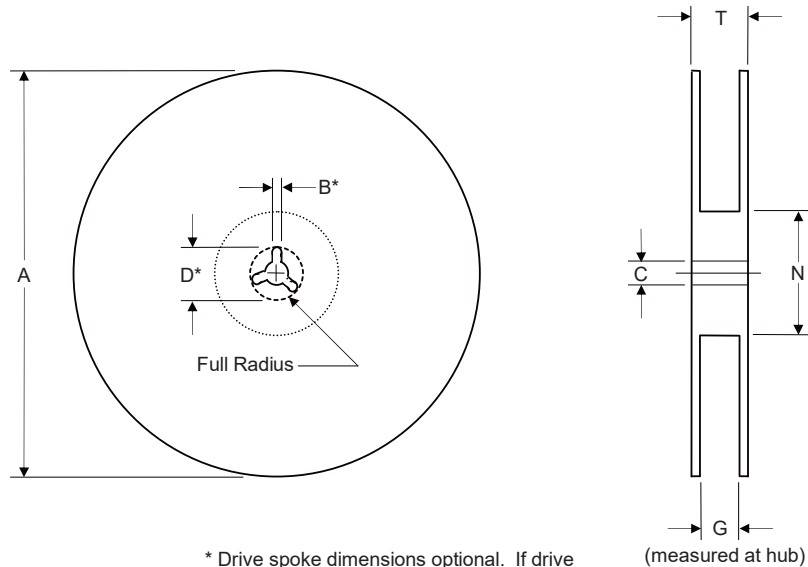

\* Drive spoke dimensions optional. If drive spoke is used then asterisked dimensions apply.

Tape Width	A	B	C	D	N	G	T
8mm	180	1.5	13.0	20.2	55	8.4	14.4
(Tolerance)	Max	Min	±0.2	Min	±5.0	+1.5	Max

## Dimensions

### Inbox Size

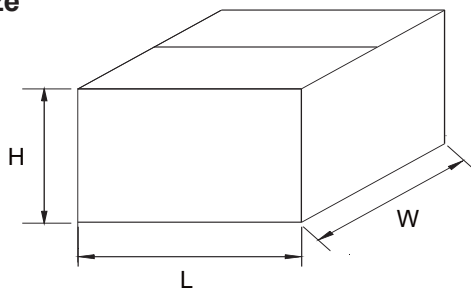

Dimension	Specification(mm typical)	
	General	MBB Bag
L	187	227
W	130	145
H	187	202

### Carton Size

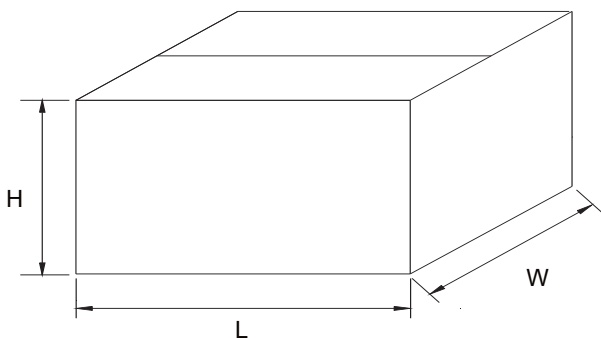

Dimension	Specification(mm typical)	
	General	MBB Bag
L	390	470
W	275	305
H	207	223