

Mechanical Data

- Surface Mount Package
- Weight: 0.0098 grams (Approximate)
- Moisture Sensitivity Level 1
- Halogen Free. "Green" Device (Note 1)
- Epoxy Meets UL 94 V-0 Flammability Rating
- Lead Free Finish/RoHS Compliant (Note2) ("P" Suffix Designates RoHS Compliant. See Ordering Information)

Note:1. free "Green" products are defined as those which contain <900ppm bromine, <900ppm chlorine (<1500ppm total Br + Cl) and <1000ppm antimony compounds.
2. High Temperature Solder Exemption Applied, see EU Directive Annex 7a.

Package 3D Photo

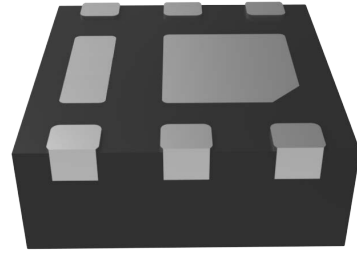

Package Outline Dimensions

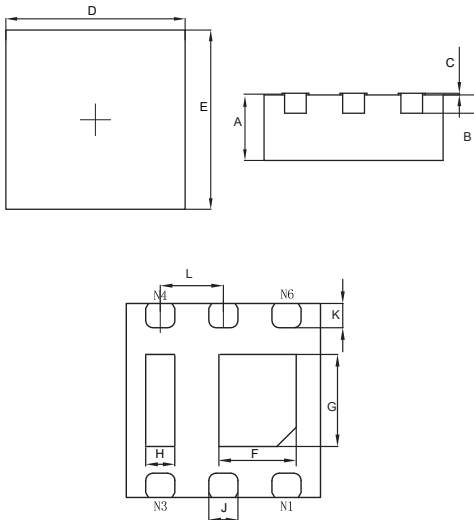

| DIM | INCHES | | MM | | NOTE |
|-----|--------|-------|-------|-------|------|
| | MIN | MAX | MIN | MAX | |
| A | 0.030 | 0.033 | 0.750 | 0.850 | |
| B | 0.008 | | 0.200 | | REF. |
| C | 0.000 | 0.002 | 0.000 | 0.050 | |
| D | 0.075 | 0.083 | 1.900 | 2.100 | |
| E | 0.075 | 0.083 | 1.900 | 2.100 | |
| F | 0.024 | 0.031 | 0.610 | 0.810 | |
| G | 0.028 | 0.036 | 0.710 | 0.910 | |
| H | 0.008 | 0.016 | 0.200 | 0.400 | |
| J | 0.010 | 0.014 | 0.250 | 0.350 | |
| K | 0.008 | 0.012 | 0.200 | 0.300 | |
| L | 0.026 | | 0.650 | | TYP. |

Suggested Solder Pad Layout

Unit:mm

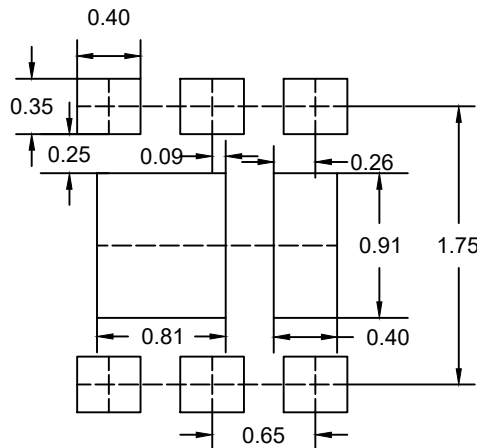

Notes:

- 1.The suggested land pattern dimensions have been provided for reference only.
- 2.For further information,please reference document IPC-7351A.

Packing Quantity

| Package | Tape Width (mm) | Reel Size (inch) | Reel Quantity | BOX Quantity | Carton Quantity |
|-------------|-----------------|------------------|---------------|--------------|-----------------|
| DFN2020-6LE | 8 | 7 | 3000 | 30K | 120K |

Note 1: These are minimum package quantities only. Minimum orders will differ. Contact the factory for more information on minimum order quantities.

Note 2: MCC Tape&reel products meets EIA-481 REV D specification.

Device Tape Orientation

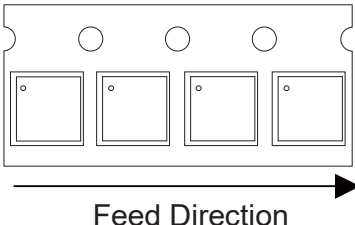
| Package | Tape Width (mm) | Tape Orientation |
|-------------|-----------------|--|
| DFN2020-6LE | 8 |  |

Embossed Carrier Tape Specifications

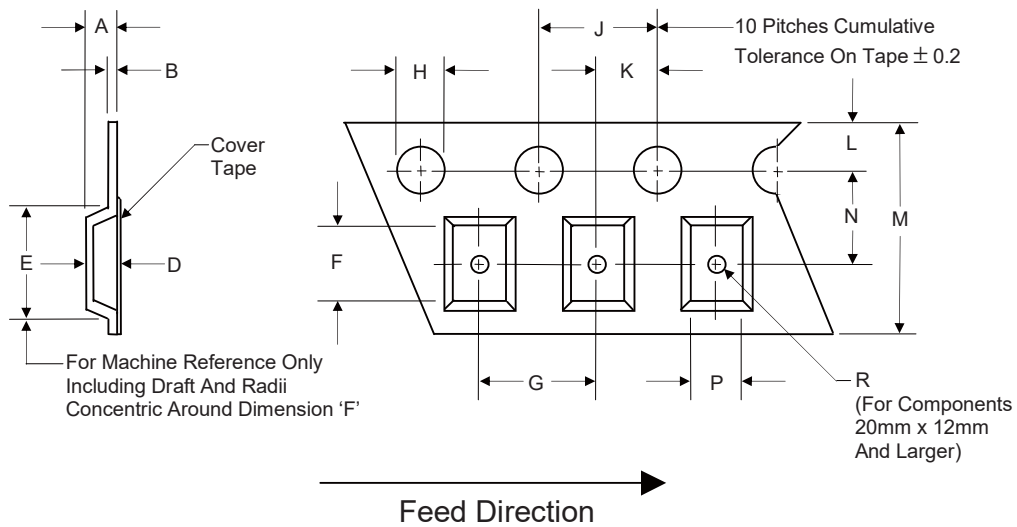

| Tape Width | H | L | J | B | D | F | P |
|-------------|---------|------|------|-----|------------|---|---|
| 8mm | 1.5 | 1.75 | 4.0 | 0.6 | See Note 3 | | |
| (Tolerance) | +0.1/-0 | ±0.1 | ±0.1 | Max | | | |

| Tape Width | E | R | N | A | K | M | G |
|-------------|-----|-----|-------|-----|-------|------|------|
| 8mm | 4.2 | 1.0 | 3.5 | 2.4 | 2.0 | 8.0 | 4.0 |
| (Tolerance) | Max | Min | ±0.05 | Max | ±0.05 | ±0.3 | ±0.1 |

Note 3: D,E,F are determined by constant size. The clearance between the part and the tape cavity must be within 0.05mm min. to 0.50mm max. for 8mm tape.

Embossed Carrier Tape Specifications



| Tape Size | R Min. |
|-----------|--------|
| 8mm | 25mm |

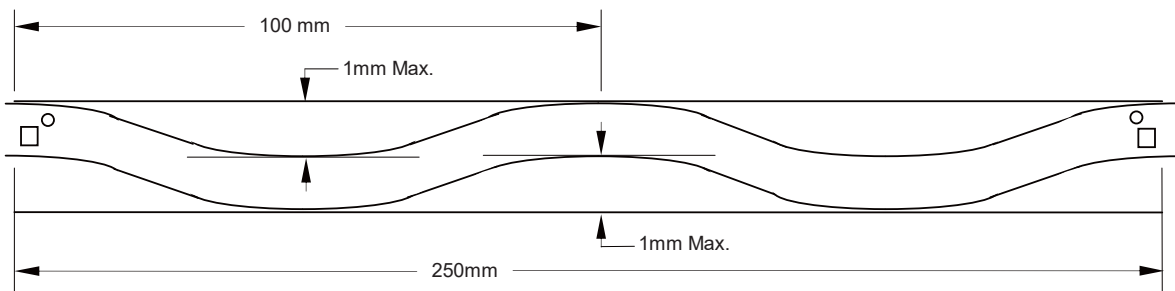

Camber (Top View)

Allowable camber to be 1mm/100mm non-accumulative over 250mm

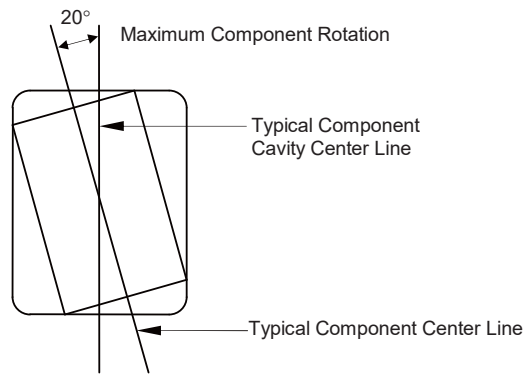

Start and Finish Specification

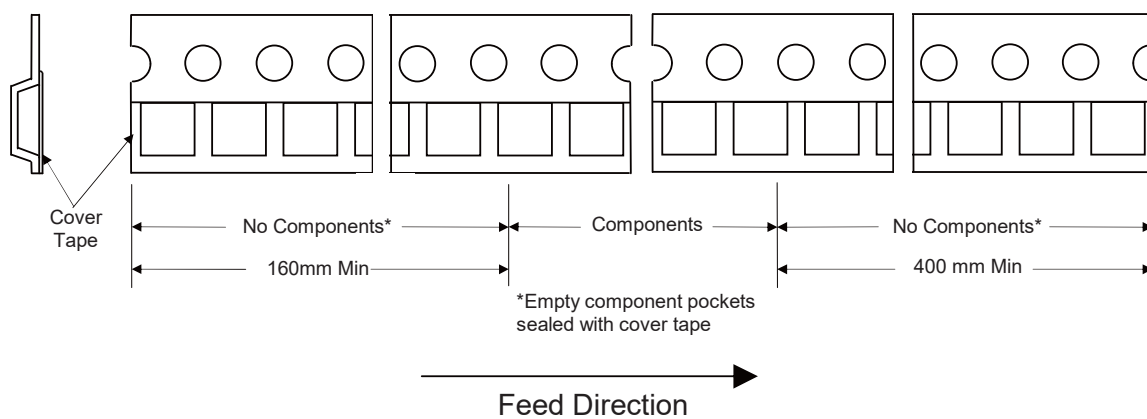

Surface Mount Reel Specifications

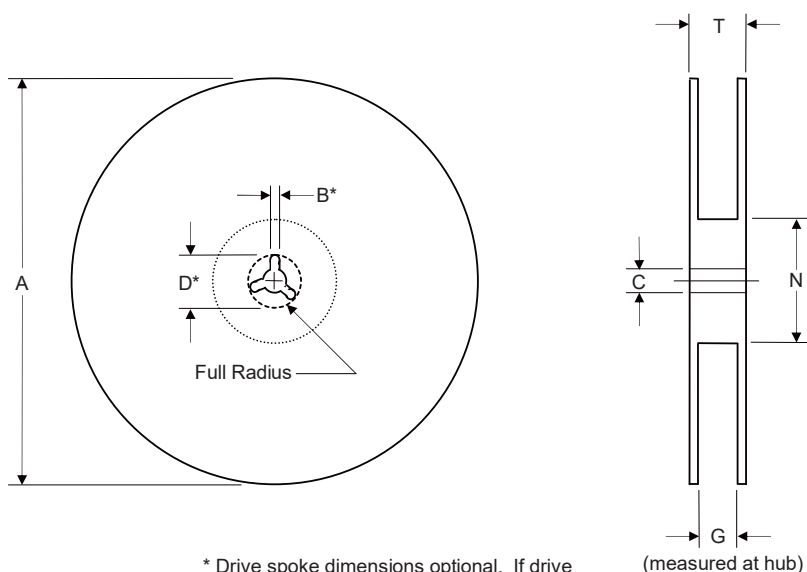

* Drive spoke dimensions optional. If drive spoke is used then asterisked dimensions apply.

| Tape Width | A | B | C | D | N | G | T |
|-------------|-----|-----|------|------|------|------|------|
| 8mm | 180 | 1.5 | 13.0 | 20.2 | 55 | 8.4 | 14.4 |
| (Tolerance) | Max | Min | ±0.2 | Min | ±5.0 | +1.5 | Max |

Dimensions

Inbox Size

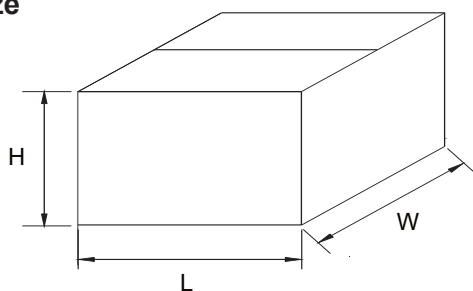

| Dimension | Specification(mm typical) | |
|-----------|---------------------------|---------|
| | General | MBB Bag |
| L | 187 | 227 |
| W | 130 | 145 |
| H | 187 | 202 |

Carton Size

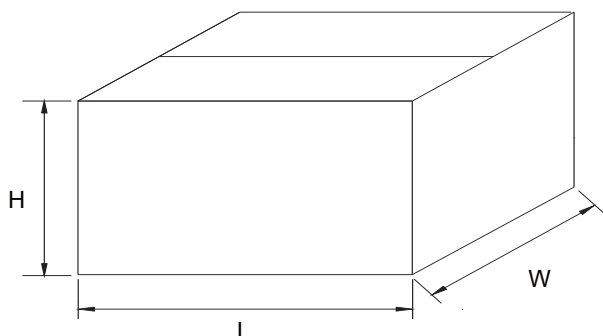

| Dimension | Specification(mm typical) | |
|-----------|---------------------------|---------|
| | General | MBB Bag |
| L | 390 | 470 |
| W | 275 | 305 |
| H | 207 | 223 |