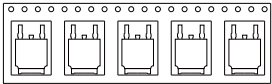

Packing Quantity and Device Tape Orientation

For Tape Reel

Package	Tape Width mm	Reel Size inch	Pitch mm	Packing Quantity			ESD/MBB Bag	Pin1 Position	Tape Orientation Feed Direction →	OPN Suffix
				Reel kpcs	Inner Box kpcs	Carton kpcs				
				mm	inch	mm			kpcs	
TO-263 /D2PAK	24	13	16	0.8	1.6	8	NA	Q2		-TP

For Tube

Package	Package Type	Packing Quantity			OPN Suffix
		Tube	Inner Box	Carton	
		Kpcs	Kpcs	Kpcs	
TO-263 /D2PAK	Tube	0.05	1	5	-BP

Note 1: All MOSFETs and other MSL3 products come with an ESD/MBB bag.

Note 2: These are minimum package quantities only. Minimum order quantities may vary. Please contact your sales representative for more information on minimum order quantities.

Note 3: MCC Tape&reel products meets EIA-481 specification.

Note 4: Please refer to the product datasheet for MSL level, RoHS and Halogen-Free compliance.

Note 5: Orientation guide for commonly used devices.

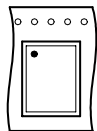
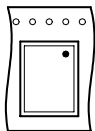
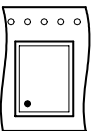
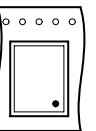
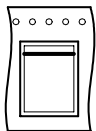
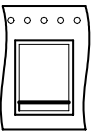
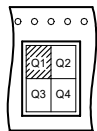
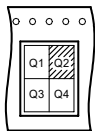
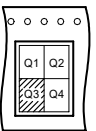
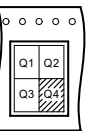
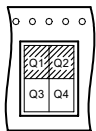
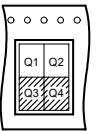
Pin1 Position	Q1	Q2	Q3	Q4	Q1Q2	Q3Q4
Orientation in Carrier						
Termination 1 Orientation by Quadrant						

Embossed Carrier Tape Specifications

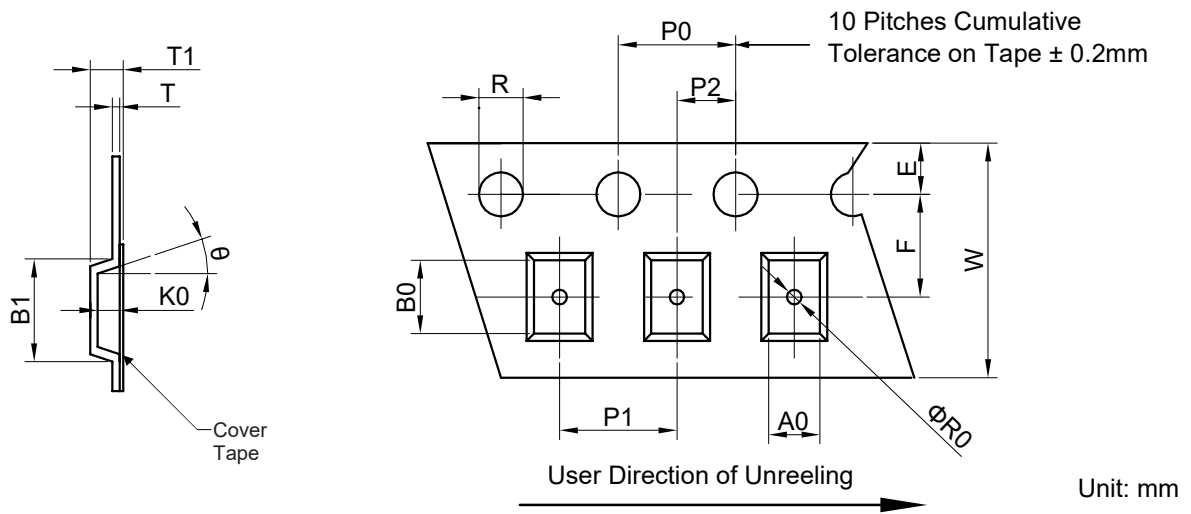

Tape Width	A0	B0	K0	B1	E	F	P0
24mm	See Note 6			See Note 7	1.75	11.5	4.0
(Tolerance)					±0.1	±0.05	±0.1

Tape Width	P1	P2	R	R0	T	T1	W
24mm	16.0	2.0	1.5	1.5	0.6	11.9	24.0
(Tolerance)	±0.1	±0.05	+0.1/-0	±0.1	Max	Max	±0.3

Note 6: A0, B0, and K0 are determined by component size. The clearance between the components and the cavity must be within 0.05 mm min to 0.50mm max.

Note 7: For machine reference only including draft and radii concentric around B0.

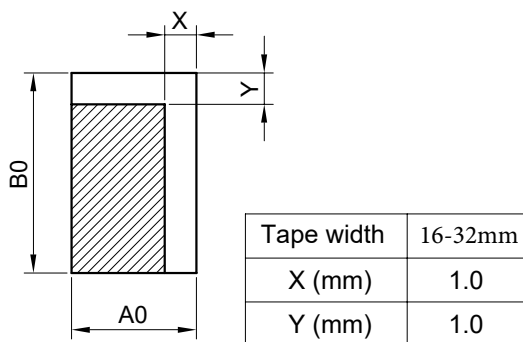

Maximum Lateral movement

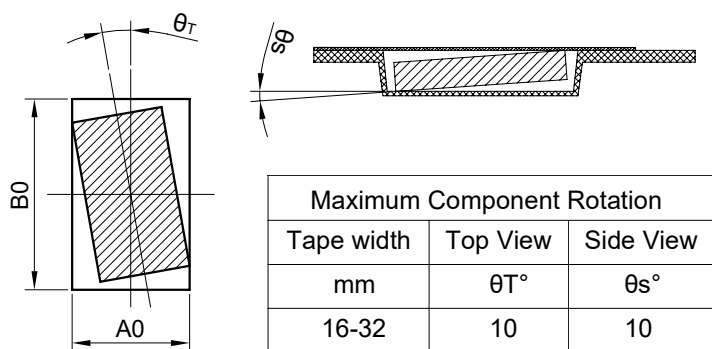

Maximum Component Rotation

Embossed Carrier Tape Specifications



Tape Size	R Min.
24mm	30mm

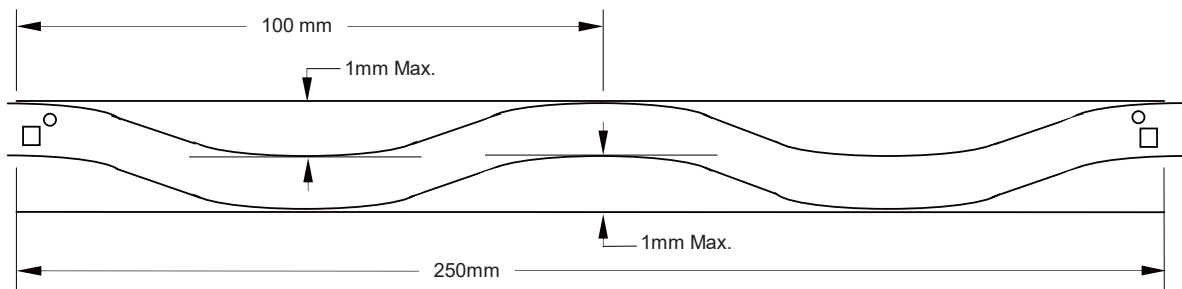

Camber (Top View)

Allowable camber to be 1mm/100mm non-accumulative over 250mm

Start and Finish Specification

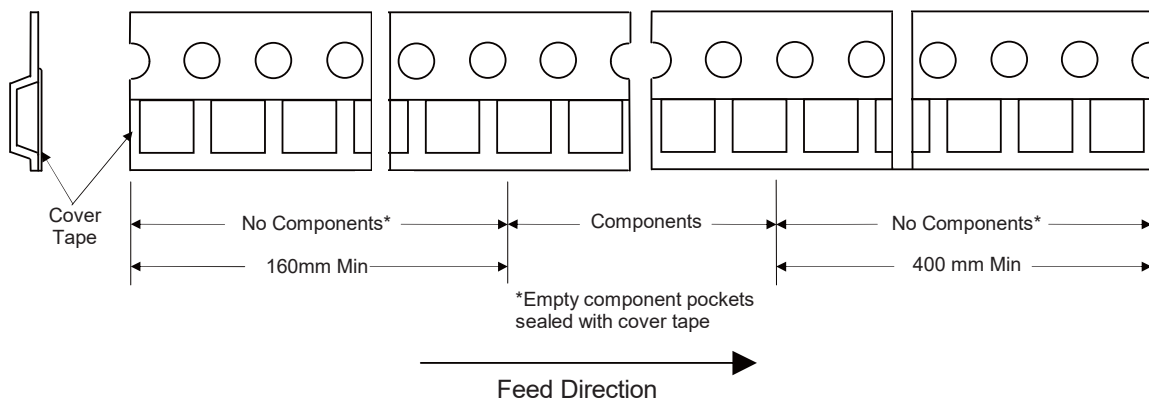

Surface Mount Reel Specifications

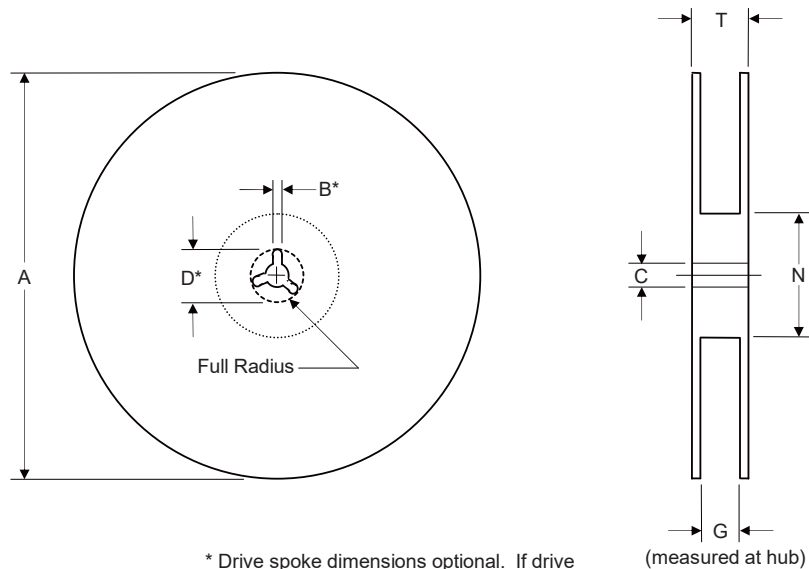

* Drive spoke dimensions optional. If drive spoke is used then asterisked dimensions apply.

Tape Width	A	B	C	D	N	G	T
24mm	360	1.5	13.0	20.2	55	24.4	30.4
(Tolerance)	Max	Min	±0.2	Min	±1.0	±1.0	Max

Dimensions

Inbox Size

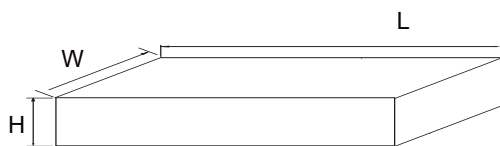

Description	Dimension	Specification(mm typical)
Length	L	345
Width	W	345
Height	H	70

Carton Size

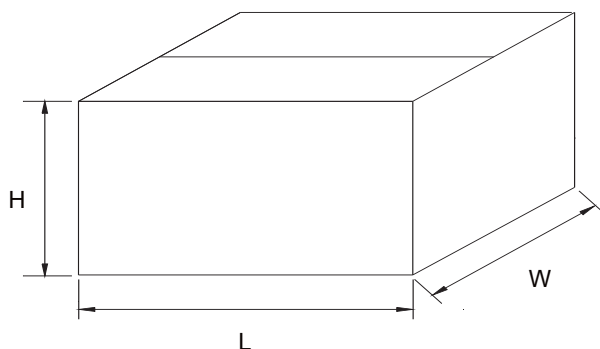

Description	Dimension	Specification(mm typical)
Length	L	360
Width	W	360
Height	H	380

Dimensions

Tube Size

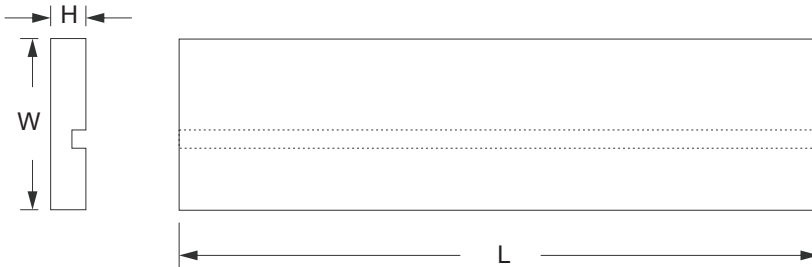

Description	Dimension	Specification(mm typical)
Length	L	530
Width	W	33
Height	H	7

Inbox Size

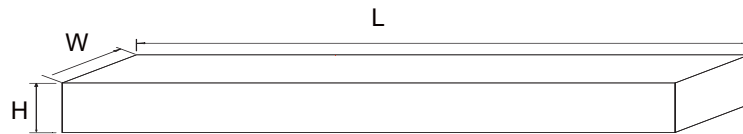

Description	Dimension	Specification(mm typical)
Length	L	560
Width	W	150
Height	H	40

Carton Size

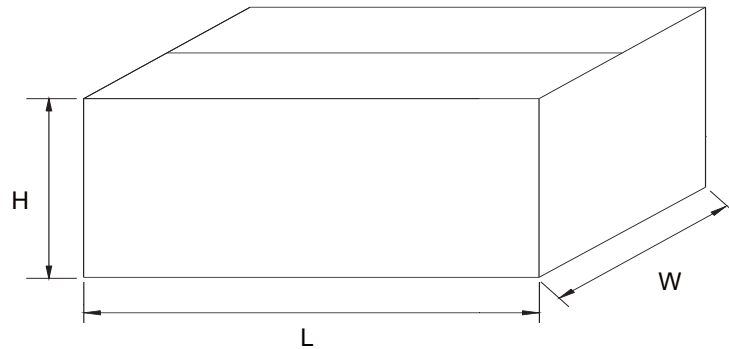

Description	Dimension	Specification(mm typical)
Length	L	570
Width	W	210
Height	H	175