

Features

- Halogen Free. "Green" Device (Note 1)
- AEC-Q101 Qualified
- Epoxy Meets UL 94 V-0 Flammability Rating
- Moisture Sensitivity Level 1
- High Reliability
- Low Reverse Current and Low Forward Voltage
- Small Surface Mount Type
- Lead Free Finish/RoHS Compliant ("P" Suffix Designates RoHS Compliant. See Ordering Information)

Maximum Ratings

- Operating Junction Temperature Range: -55°C to +125°C
- Storage Temperature Range: -55°C to +150°C
- Thermal Resistance: 667°C/W Junction to Ambient(Note 2)

MCC Part Number	Repetitive Peak Reverse Voltage V_{RRM}	RMS Reverse Voltage $V_{R(RMS)}$	DC Blocking Voltage V_R
RB521S-30HE3	30V	21V	30V

Electrical Characteristics @ 25°C Unless Otherwise Specified

Parameter	Symbol	Value
Average Rectified Current	$I_{F(AV)}$	200mA
Peak Forward Surge Current (t=8.3ms)	I_{FSM}	1A
Power Dissipation	P_D	150mW

Note: 1. Halogen free "Green" products are defined as those which contain <900ppm bromine, <900ppm chlorine (<1500ppm total Br + Cl) and <1000ppm antimony compounds.

2. Valid Provided that Terminals are Kept at Ambient Temperature.

Internal Structure and Marking Code

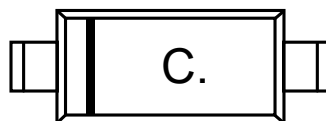

**200 mA
Schottky Barrier
Diode
30 Volts**

SOD-523

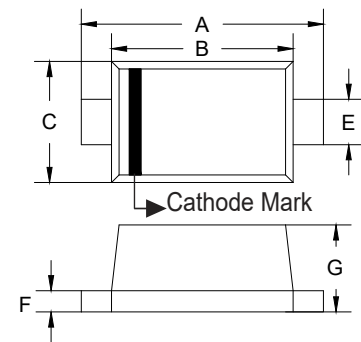

DIM	DIMENSIONS				NOTE
	INCHES		MM		
	MIN	MAX	MIN	MAX	
A	0.059	0.067	1.50	1.70	
B	0.043	0.051	1.10	1.30	
C	0.030	0.033	0.75	0.85	
E	0.010	0.014	0.25	0.35	
F	0.003	0.008	0.08	0.20	
G	0.020	0.026	0.50	0.65	

Suggested Solder Pad Layout

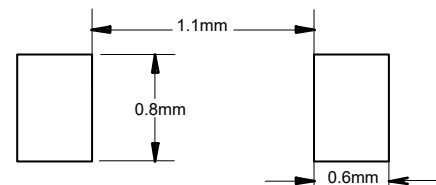

Electrical Characteristics @ 25°C (Unless Otherwise Specified)

Parameter	Symbol	Conditions	Min.	Typ.	Max.	Units
Reverse Breakdown Voltage	V_{BR}	$I_R=100\mu A$	30			V
Forward Voltage	V_F	$I_F=200mA$			0.50	V
Reverse Current	I_R	$V_R=10V, T_J=25^\circ C$			30	μA
Junction Capacitance	C_J	$V_R = 0V, f = 1MHz$			30	pF
Reverse Recovery Time	t_{rr}	$I_F=I_R=10mA,$ $I_{rr}=0.1*I_R, R_L=100\Omega$			10	ns

Curve Characteristics

Fig. 1 - Typical Instantaneous Forward Characteristics

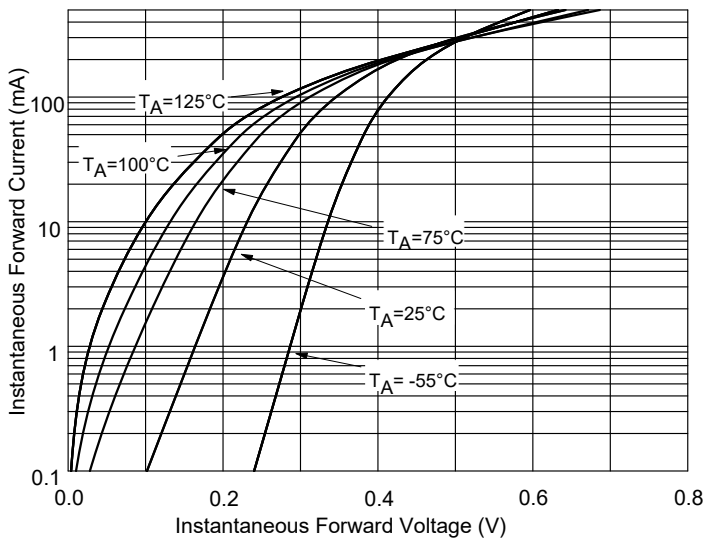

Fig. 2 - Typical Reverse Leakage Characteristics

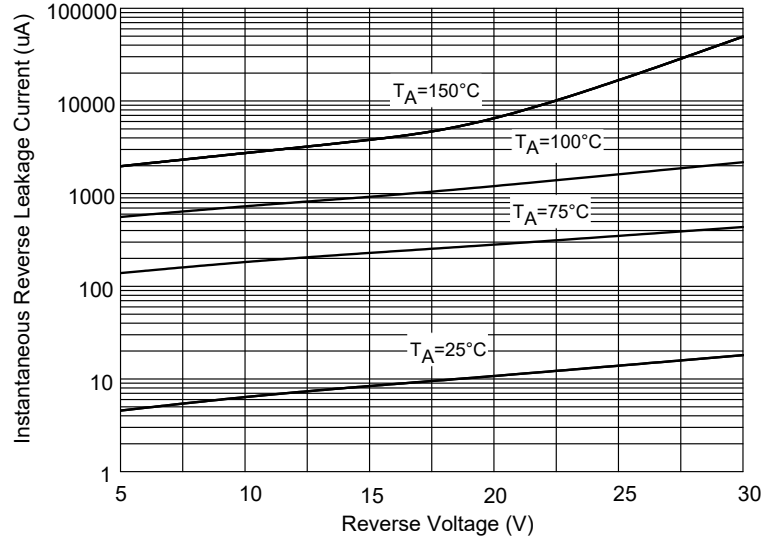

Fig. 3 - Capacitance Characteristics

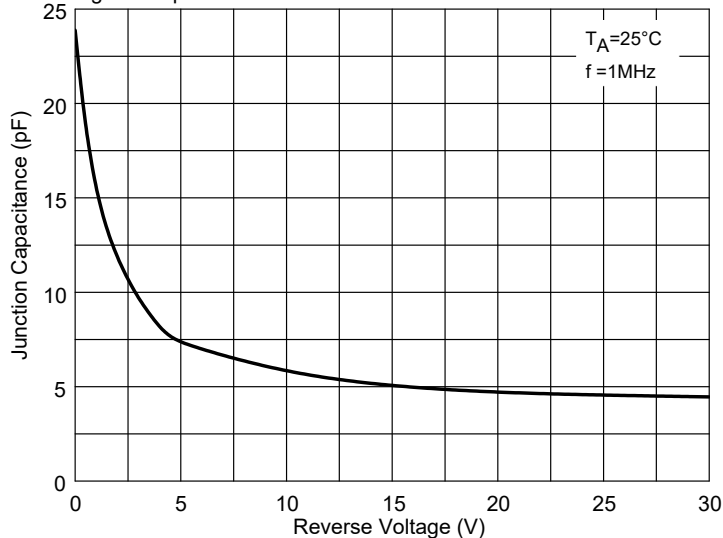
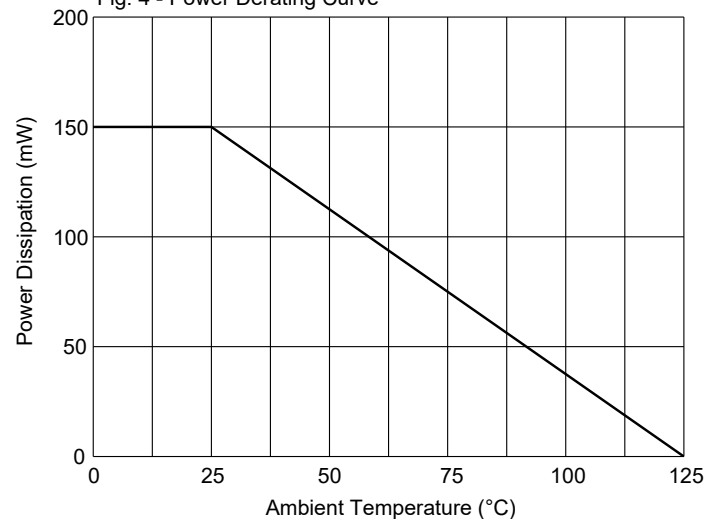

Fig. 4 - Power Derating Curve



Ordering Information

Device	Packing
Part Number-TP	Tape&Reel: 8Kpcs/Reel

*****IMPORTANT NOTICE*****

Micro Commercial Components Corp. reserves the right to make changes without further notice to any product herein to make corrections, modifications, enhancements, improvements, or other changes. **Micro Commercial Components Corp.** does not assume any liability arising out of the application or use of any product described herein; neither does it convey any license under its patent rights, nor the rights of others. The user of products in such applications shall assume all risks of such use and will agree to hold **Micro Commercial Components Corp.** and all the companies whose products are represented on our website, harmless against all damages. **Micro Commercial Components Corp.** products are sold subject to the general terms and conditions of commercial sale, as published at <https://www.mccsemi.com/Home/TermsAndConditions>.

*****LIFE SUPPORT*****

MCC's products are not authorized for use as critical components in life support devices or systems without the express written approval of Micro Commercial Components Corporation.

*****CUSTOMER AWARENESS*****

Counterfeiting of semiconductor parts is a growing problem in the industry. Micro Commercial Components (MCC) is taking strong measures to protect ourselves and our customers from the proliferation of counterfeit parts. MCC strongly encourages customers to purchase MCC parts either directly from MCC or from Authorized MCC Distributors who are listed by country on our web page cited below. Products customers buy either from MCC directly or from Authorized MCC Distributors are genuine parts, have full traceability, meet MCC's quality standards for handling and storage. **MCC will not provide any warranty coverage or other assistance for parts bought from Unauthorized Sources.** MCC is committed to combat this global problem and encourage our customers to do their part in stopping this practice by buying direct or from authorized distributors.