



Micro Commercial Components

Micro Commercial Components  
 20736 Marilla Street Chatsworth  
 CA 91311  
 Phone: (818) 701-4933  
 Fax: (818) 701-4939

**Features**

- Lead Free Finish/RoHS Compliant(Note 1) ("P" Suffix designates RoHS Compliant. See ordering information)
- Peak Reverse Voltages Through 1000 Volts
- Glass Passivated Chip and High Surge Current Capability
- Case Material: Molded Plastic. UL Flammability Classification Rating 94V-0 and MSL Rating 1

**Maximum Ratings**

- Operating Temperature: -55°C to +150°C
- Storage Temperature: -55°C to +150°C

MCC Catalog Number	Device Marking	Maximum Recurrent Peak Reverse Voltage	Maximum RMS Voltage	Maximum DC Blocking Voltage
30S1	30S1	100V	70V	100V
30S2	30S2	200V	140V	200V
30S3	30S3	300V	210V	300V
30S4	30S4	400V	280V	400V
30S5	30S5	500V	350V	500V
30S6	30S6	600V	420V	600V
30S8	30S8	800V	560V	800V
30S10	30S10	1000V	700V	1000V

**Electrical Characteristics @ 25°C Unless Otherwise Specified**

Average Forward Current	$I_{F(AV)}$	3.0A	$T_A = 100^\circ\text{C}$
Peak Forward Surge Current	$I_{FSM}$	80A	8.3ms, half sine
Maximum Instantaneous Forward Voltage	$V_F$	1.0V	$I_{FM} = 3.0\text{A}; T_J = 25^\circ\text{C}(\text{Note } 2)$
Maximum DC Reverse Current At Rated DC Blocking Voltage	$I_R$	5 $\mu\text{A}$ 10 $\mu\text{A}$	$T_J = 25^\circ\text{C}$ $T_J = 100^\circ\text{C}$
Typical Junction Capacitance	$C_J$	100pF	Measured at 1.0MHz, $V_R=4.0\text{V}$

Notes:1.High Temperature Solder Exemption Applied, see EU Directive Annex 7.  
 2.Pulse test: Pulse width 300  $\mu\text{sec}$ , Duty cycle 1%

**30S1  
 thru  
 30S10**

**3 Amp  
 Medium Power  
 Silicon Rectifier  
 50 - 1000 Volts**

T-18

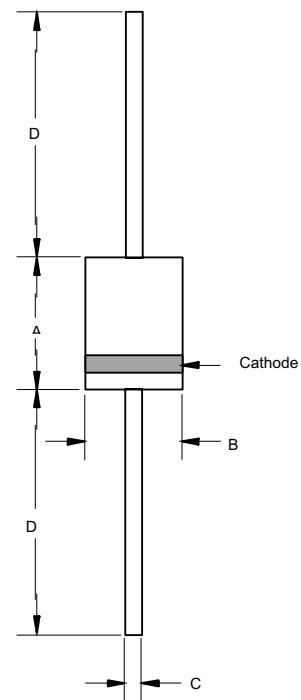

DIM	INCHES		MM		NOTE
	MIN	MAX	MIN	MAX	
A	.330	.350	8.39	8.89	
B	.130	.145	3.31	3.68	
C	.038	.042	0.97	1.06	
D	1.00	---	25.40	---	

# 30S1 thru 30S10

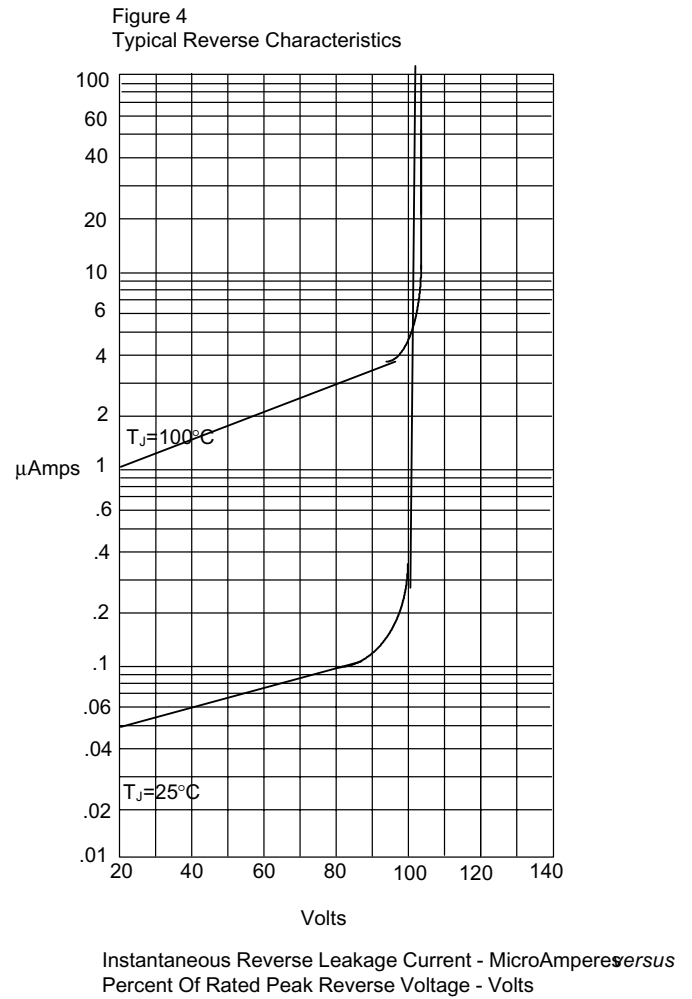
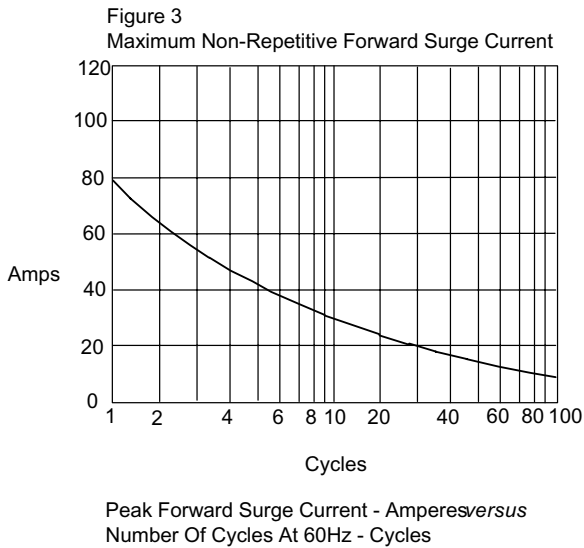
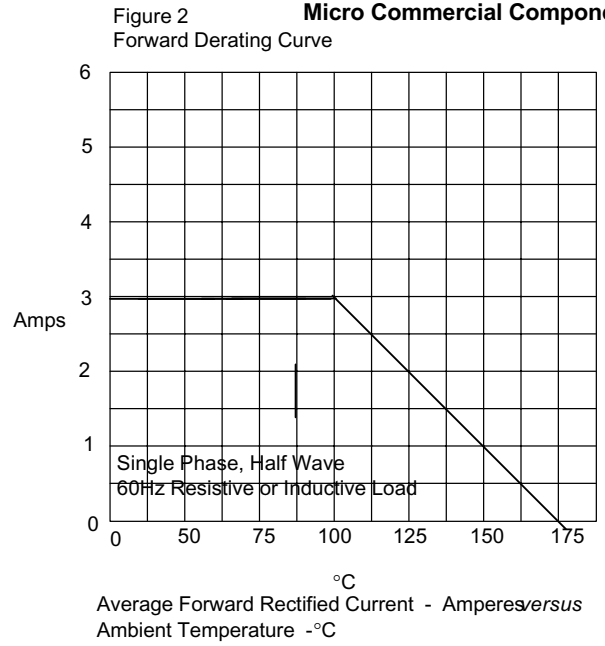
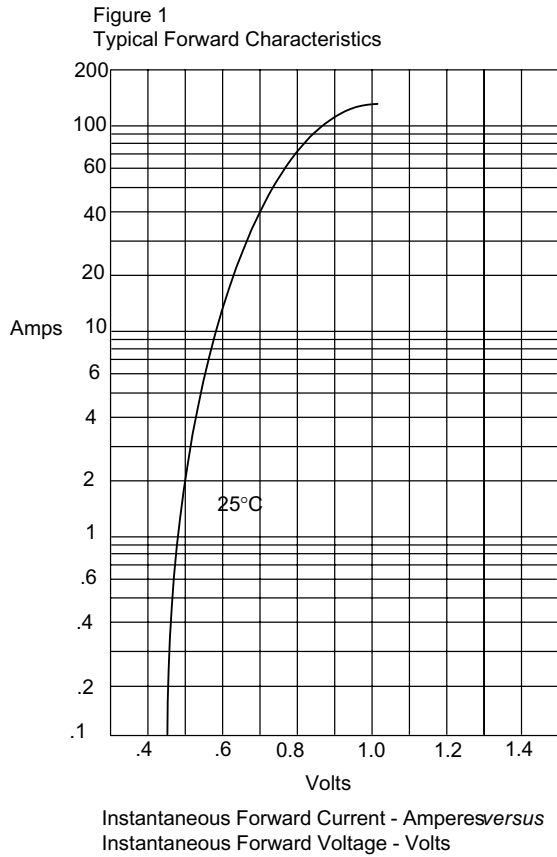



Micro Commercial Components

## Ordering Information

Device	Packing
(Part Number)-TP	Tape&Reel; 3Kpcs/Reel
(Part Number)-AP	Ammo Packing;3Kpcs/AmmoBox
(Part Number)-BP	Bulk;1Kpcs/Box

**\*\*\*IMPORTANT NOTICE\*\*\***

*Micro Commercial Components Corp.* reserve the right to make changes without further notice to any product herein to make corrections, modifications , enhancements , improvements , or other changes . *Micro Commercial Components Corp.* does not assume any liability arising out of the application or use of any product described herein; neither does it convey any license under its patent rights ,nor the rights of others . The user of products in such applications shall assume all risks of such use and will agree to hold *Micro Commercial Components Corp.* and all the companies whose products are represented on our website, harmless against all damages.

**\*\*\*APPLICATIONS DISCLAIMER\*\*\***

Products offer by *Micro Commercial Components Corp.* are not intended for use in Medical, Aerospace or Military Applications.