

Mechanical Data

- Surface Mount Package
- Weight: 0.0020 grams (Approximate)
- Moisture Sensitivity Level 1
- Halogen Free. "Green" Device (Note 1)
- Epoxy Meets UL 94 V-0 Flammability Rating
- Lead Free Finish/RoHS Compliant (Note2) ("P" Suffix Designates RoHS Compliant. See Ordering Information)

Note:1. free "Green" products are defined as those which contain <900ppm bromine, <900ppm chlorine (<1500ppm total Br + Cl) and <1000ppm antimony compounds.
2. High Temperature Solder Exemption Applied, see EU Directive Annex 7a.

Package 3D Photo

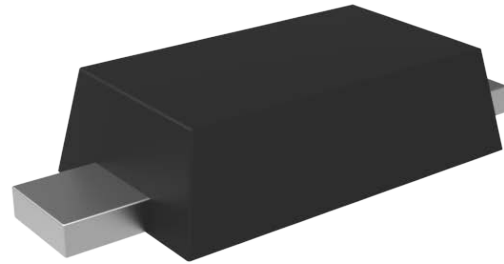

Package Outline Dimensions

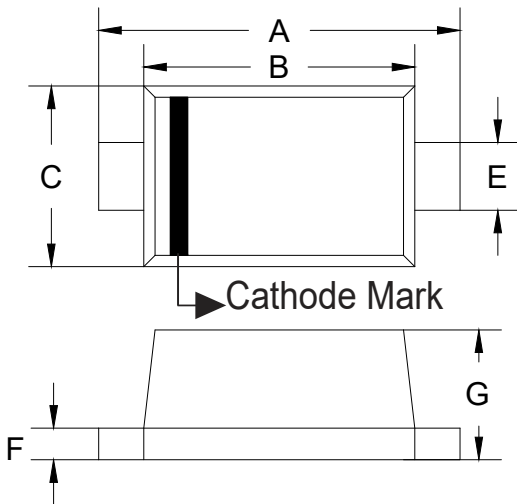

DIM	INCHES		MM		NOTE
	MIN	MAX	MIN	MAX	
A	0.059	0.067	1.50	1.70	
B	0.043	0.051	1.10	1.30	
C	0.030	0.033	0.75	0.85	
E	0.010	0.014	0.25	0.35	
F	0.003	0.008	0.08	0.20	
G	0.020	0.026	0.50	0.65	

Suggested Solder Pad Layout

Unit:mm

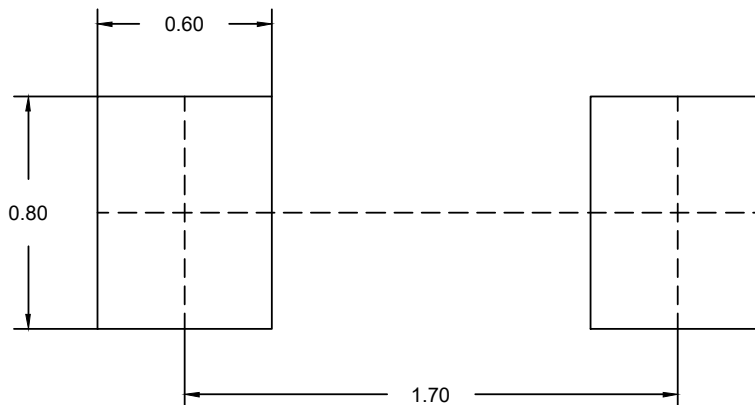

Notes:

- 1.The suggested land pattern dimensions have been provided for reference only.
- 2.For further information,please reference document IPC-7351A.

Packing Quantity

Package	Tape Width (mm)	Reel Size (inch)	Reel Quantity	BOX Quantity	Carton Quantity	Remark
SOD-523	8	7	8000	80K	320K	Part Number-TP
			3000	30K	120K	Part Number-T3P

Note 1: These are minimum package quantities only. Minimum orders will differ. Contact the factory for more information on minimum order quantities.

Note 2: MCC Tape&reel products meets EIA-481 REV D specification.

Device Tape Orientation

Package	Tape Width (mm)	Tape Orientation	
		Part Number-TP	Part Number-T3P
SOD-523	8		

Embossed Carrier Tape Specifications

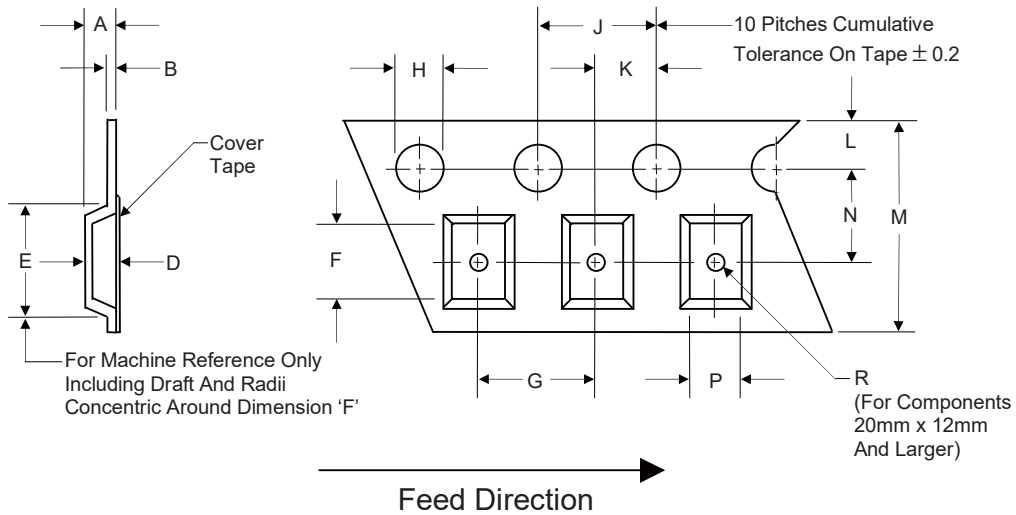

Tape Width	H	L	J	B	D	F	P
8mm	1.5	1.75	4.0	0.6	See Note 3		
(Tolerance)	+0.1/-0	±0.1	±0.1	Max			

Tape Width	E	R	N	A	K	M	G
8mm	4.2	1.0	3.5	2.4	2.0	8.0	2.0 or 4.0
(Tolerance)	Max	Min	±0.05	Max	±0.05	±0.3	±0.1

Note 3: D,E,F are determined by constant size. The clearance between the part and the tape cavity must be within 0.05mm min. to 0.50mm max. for 8mm tape.

Note 4: G=4.0mm is for the tape which is 3000pcs/reel with no skip.

Embossed Carrier Tape Specifications



Tape Size	R Min.
8mm	25mm

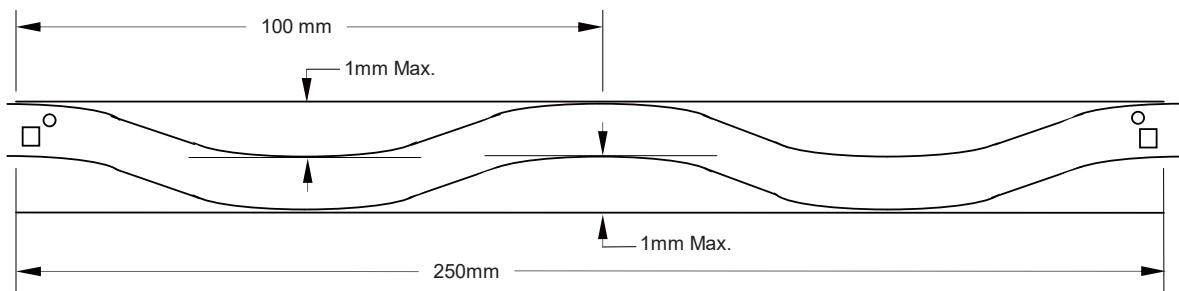

Camber (Top View)

Allowable camber to be 1mm/100mm non-accumulative over 250mm

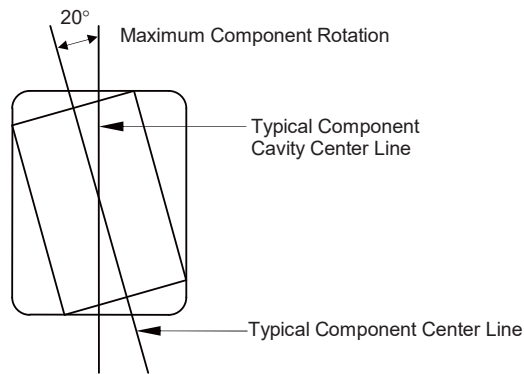

Start and Finish Specification

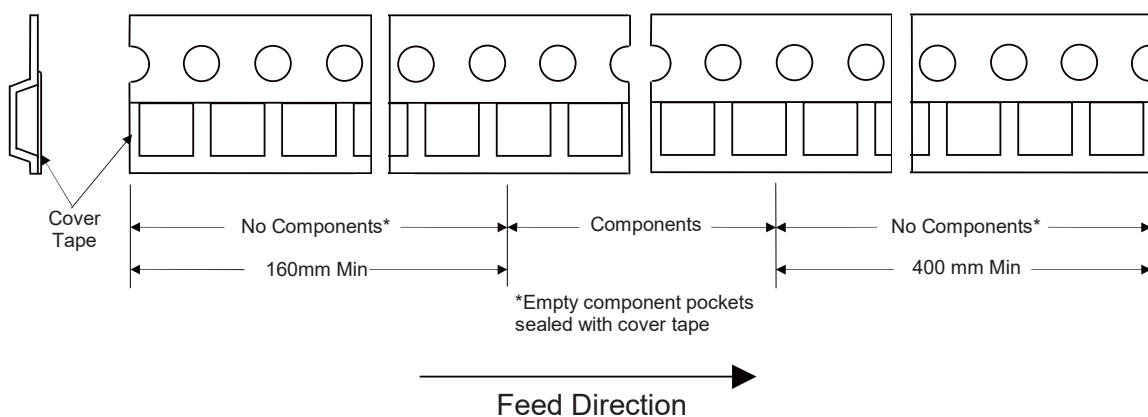

Surface Mount Reel Specifications

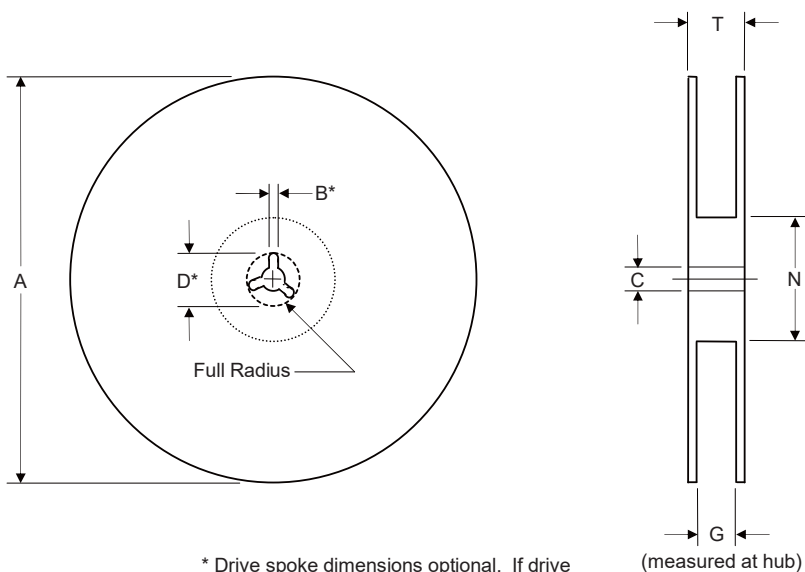

* Drive spoke dimensions optional. If drive spoke is used then asterisked dimensions apply.

Tape Width	A	B	C	D	N	G	T
8mm	180	1.5	13.0	20.2	55	8.4	14.4
(Tolerance)	Max	Min	±0.2	Min	±5.0	+1.5	Max

Dimensions

Inbox Size

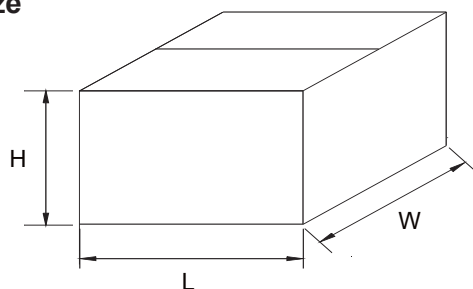

Dimension	Specification(mm typical)	
	General	MBB Bag
L	187	227
W	130	145
H	187	202

Carton Size

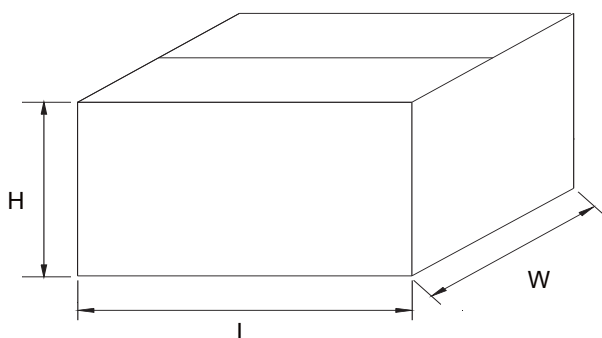

Dimension	Specification(mm typical)	
	General	MBB Bag
L	390	470
W	275	305
H	207	223